

**gorenje**

BY

**S+ARCK<sup>®</sup>**

DESIGNED  
BY  
S+ARCK,<sup>®</sup>  
DEFINED  
BY  
YOU.



# GORENJE BY STARCK®

Gorenje's new collection of kitchen appliances is designed by one of the most unique creators acknowledged worldwide, Philippe Starck. It is built with the highest technologies and cutting edge energy efficiency.

The collection is composed of a comprehensive range of ovens, hobs, hoods, refrigerators and other appliances all in 100% matching design whose elegance lies in "the discretion of its high quality and its pure lines."

The minimalistic design with high-end reflective glass and stainless steel will blend smoothly with its environment and will literally become a reflection of your lifestyle and personality.

Carefully selected details like metal effects of stainless steel and orange handles with their reflections will bring an extra spark of life and an elegant final touch to your kitchen.

"With this collection we solved the paradox: to create appliances that are technologically impeccable and still have a cozy, warm and human feeling to them."

Philippe Starck

Discover the collection and create your own, high-end unique kitchen.







# MEET S+ARCK®

**Philippe Starck** is an internationally acclaimed French creator.

His profound comprehension of contemporary mutations, his love of ideas, his desire to defend the intelligence of usefulness – and the same usefulness of intelligence – have accompanied one iconic creation after the other. From everyday products such as furniture and lemon squeezers, to revolutionary mega-yachts, individual windmills, electric bikes or hotels and restaurants that aspire to be wondrous, stimulating and intensely vibrant places.

His 10.000 creations, his global fame and his tireless protean inventiveness, never made him forget the essential, his mission and vision: creation, whatever shape it takes, must make life better for the largest number of people possible, through objects to be »good« before being »beautiful«.

“Every object, every shape, every style must have a meaning,  
and it is this meaning that influences us every day.”

Philippe Starck

By designing his first collection with Gorenje, Philippe Starck confirms his duty to serve his community by providing the best quality at the right price, with products created with Intelligence, Quality and Honesty.

Always placing the users at the heart of his creative process, the Gorenje by S+ARCK kitchen line was designed to match and reflect every lifestyle and personality.





A black and white close-up portrait of Philippe Starck. He has a beard and is looking directly at the camera with a thoughtful expression. His right hand is raised to his chin, with his fingers resting against his cheek. The background is a plain, dark grey color.

“Every object, every shape, every style must have a meaning, and it is this meaning that influences us every day.”

Philippe Starck

# OVENS

Express your creativity with one of the largest capacities available and enjoy the perfect results of MultiFlow 360° ventilation system.









## HomeMade shape

Traditional wood-burning style dishes in the modern environment of your home

The characteristic rounded shape is one of the most beneficial features of Gorenje ovens. Inspired by traditional wood-burning ovens, it enables hot air to move around freely. Since the food is heated evenly and from all sides, it is always perfectly done: crispy on the outside and juicy on the inside. Combined with the MultiFlow 360° ventilation system, it makes baking on all 5 levels possible.



## MultiFlow 360°

Demand only the perfect results

MultiFlow 360° guarantees the optimal circulation of heat within the oven. Due to smartly positioned ventilation openings on the back wall and the unique round shape, air is spread evenly throughout the oven. The fan pushes hot air around the entire oven volume, making the food perfectly baked on all sides. The dynamic air movement allows simultaneous baking on many levels without smells and flavours mixing together.







## BigSpace

Impress with your creativity

The new Gorenje by Starck oven conceals a shape within the upper part. Now the optimised airflow circulates inside at an even greater volume, circling completely freely. The increased capacity allows preparation of larger baking trays and larger quantities of food, while their outside dimensions remain the same. Now you can use up to 5 levels at the same time. Capacities range up to 75 l in standard ovens and up to 53 l in microwave ovens, which is amongst the largest available on the market.

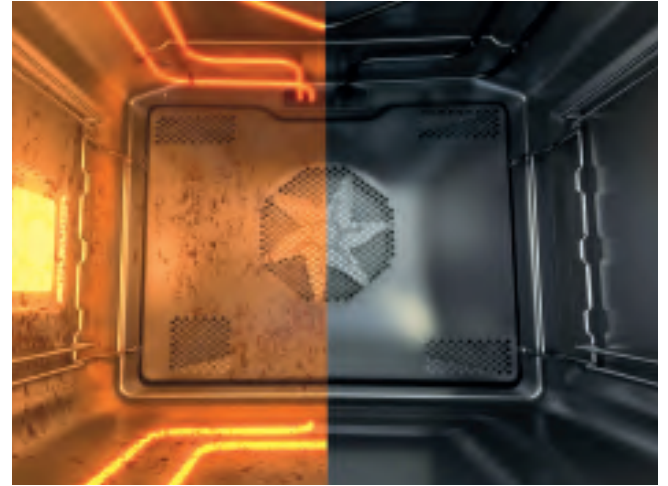

## PyroClean

So you can save time for more important things

Pyrolytic cleaning is the most efficient and advanced way to clean an oven. The high cleaning temperature of up to 500°C leaves the oven completely clean, without a spot of grease. Gentle cleaning is over in 90 minutes, medium intensity cleaning ends in 120 minutes, while very intensive cleaning takes only 150 minutes where the effect is according to the duration. At the end, only the leftovers need to be wiped away. The oven is locked during and immediately after the cleaning process, which makes it family-friendly.



## GentleClose

Your kitchen, smooth & silent

Only a soft touch is needed to close the oven door smoothly, without any noise.



## DiracTOUCH

Perfect results are always at your fingertips

Simple oven control by touching a screen. Large and intelligible symbols take the remarkable technology to another level with clarity and simplicity of use.

# MICROWAVE OVENS

Take care of every detail and serve professional dishes in the privacy of your home.









## Inverter Technology

Eat tasty and nutritious food in no time

Because of Inverter technology the energy is evenly distributed instead of pulsating. As a result, the food retains its initial structure, including its vitamins, minerals and fibres. The advantages of the even energy distribution are particularly welcome when reheating or defrosting, and when cooking liquids. The overall microwaving time is shorter, which lowers energy consumption as well.





## Stirrer Technology

Say goodbye to uneven heating

The Stirrer technology permits a standard-size baking tray to be placed in a microwave oven. The oven's entire width is used, saying goodbye to conventional turntables and uneven heating. The advanced microwave distribution system heats the food uniformly across the entire volume.



## MultiUse

Enjoy all the advantages of combined operation

Built-in combined and microwave ovens deliver all the advantages of microwaves, hot air, and grill. The multi-level microwave power setting speeds up the cooking process while the hot air makes sure the food is well done. Combined operation, using grill and hot air at the same time, leads to excellent results when cooking large chunks of white meat, while grill and microwave combination will speed up roasting smaller chunks of meat, baking pizzas etc. Built in - microwave oven can also be used as a conventional oven.



## AutoMenu

Cooking has never been so simple

Number of preset programs enables even simpler preparation of certain dishes. Just select the type of food and enter its weight, and the oven will automatically adjust the power and cooking time accordingly.



## Touch opening

Simple opening by touch of your fingertips

Modern sensor technology allows simple opening of the microwave oven just by touching an symbol control panel. The whole surface remains perfectly smooth with pure and simple forms.

# HOBS

Prepare your favourite dishes in no time with the extremely time-efficient induction hob with PowerBoost Supreme system.











## XpandZone

When you expect a lot of guests

XpandZone allows cooking on almost the entire surface of the induction hob. When the XpandZone mode is activated, the cooking zones on the left or right side of the hob are combined into one extra-large cooking zone. Combined cooking zones allow more space and freedom for cooking, space for larger cookware, or space for several smaller pots or pans that can be placed anywhere on the combined cooking zone.



## PowerBoost Supreme

When time is your most precious value

PowerBoost Supreme provides extreme heat intensity to the pot and significantly cuts waiting time. It takes just 4.2 minutes to boil 2l of water, which is extremely time-efficient.





## TouchControl

Now anyone can have the magic touch

Modern sensor technology allows clear and simple touch control operation literally with your fingertips. The control surface is perfectly smooth and easy to clean.



## Timer

Never miss the right time

The timer ensures the hob will switch off automatically at the desired time notifying you with a sound alarm.



## ChildLock

ChildLock option is excellent for those who have children at home. Leaving them in a kitchen unauthorized has never been safer, since this option prevents them from resetting any parameters.

# HOODS

Keep your kitchen always fresh with a timer  
and AdaptTech sensor.









## AdaptTech

So you can focus on cooking

The sensor detects the level of impurities or steam, humidity and gases. The hood automatically adjusts the fan speed accordingly or even completely stops the fan when it is no longer needed.





## Touch on inox

Everything is under your control

Gorenje's cutting edge sensor technology makes it possible for you to operate your inox hood quite literally with your fingertips. Since everything is hidden behind the inox, the whole surface remains perfectly smooth with pure and simple forms.



## TouchFree coating

Always a clear reflection of who you are

All stainless steel surfaces are coated with a special TouchFree film that prevents fingerprints markings, leaving the surface always shiny and making cleaning much easier.

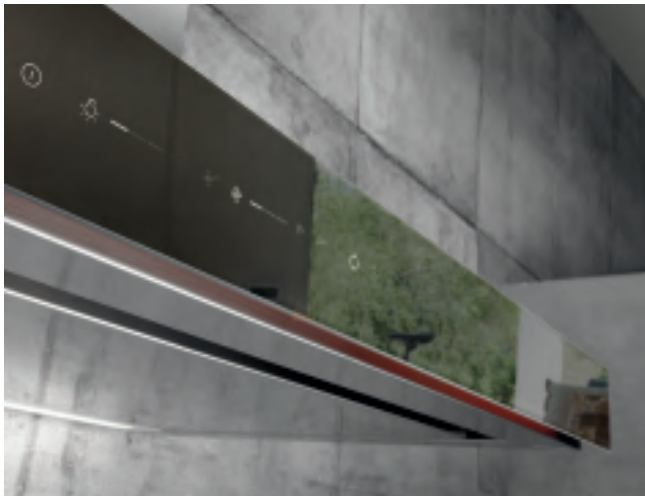

## Timer and refresh

Keeps your kitchen always fresh

Gorenje hoods can be automatically switched off in 10, 20 or 30 minutes. The refresh function is activated every hour and automatically starts refreshing the air for five minutes.



## P.A.S. System

Listen to only what you want to hear

The innovative parametric air suction system redirects air extraction from the central part to the outer edges of the hood. This approach optimises energy consumption, reduces noise and makes air extraction considerably more efficient.

# COOLING

Have just like garden-fresh food always at hand with humidity control and AdaptTech smart system.







[gorenje.com](http://gorenje.com)

We reserve the right to change model and specifications without notice.



## IonAir with the MultiFlow 360° function

Every shelf should be the best shelf

Advanced technology in the refrigerators emulates the natural process of ionization to keep the food fresh longer. Negatively charged ions generated by the appliance continuously refresh the air to mimic a natural microclimate, thus creating the ideal environment for fresh food. The MultiFlow 360° ventilation system evenly distributes the ionized air through 14 ventilation slots to maintain constant temperature on every shelf.



## AdaptTech

A refrigerator that reflects your habits

This smart system was devised to maintain the optimum temperature in the refrigerator regardless of how frequently you open the door. When the door is opened, the temperature suddenly rises and the food is exposed to a thermal shock which in turn causes it to perish sooner. The refrigerator continuously monitors and analyzes the way you use it. Thus, it can predict when you will open the fridge door and just before you do, it decreases the temperature by 1 or 2 °C to make sure constant temperature is maintained and that the food stays fresh and full of nutrients.





## NoFrost Plus

Freezes only what you want to freeze

One of the best cooling systems in the market, installed in the freezer compartment, prevents the accumulation of ice and frost to keep the power consumption low, while in the refrigerator compartment, it maintains an ideal microclimate for fresh food. Circulation of the cold air prevents the food from drying out and retains its vitamins and minerals.



## CrispZone drawer

The freshness you expect from the best

CrispZone is one of the largest fruit and vegetables bins in the market, designed to preserve the nutrients and prolong the freshness of your food. Low temperature extend the freshness of your produce.



## MultiShelf

A refrigerator that adapts to your needs

A special highly flexible shelf with special bottle retainers could be adapted to any need. It could be a shelf for storing food placed anywhere in the fridge or a special bottle rack with design bottle retainers that can hold up to 9 bottles.

# DRAWERS

Make sure that your food tastes every bit as good as it should until serving.









## Warming drawer

*So you can easily take care of every detail*

The functionality of compact ovens can be further upgraded by a warming drawer, available separately. The drawer is installed right under the oven, the entire composition fitting perfectly into the furniture element designed for classic built-in ovens. The drawer is used for warming dishware, but also food.





## StayWarm

Keeps your cooking in perfect shape

The StayWarm function keeps food at a constant temperature of 70°C until the time is right to serve the meal. The food retains its original flavour and temperature until it is served.



## WarmPlate

Serve professional dishes in the comfort of your home

Warmed plates prevent the loss of flavour and ensure that food tastes every bit as good as it should: from soups to pastas and steamed vegetables. WarmPlate will keep your crockery at precisely the right temperature – anywhere between 30 and 80°C. Enjoy professional service in the privacy of your home!



## Yoghurt

When you want a healthy choice

A special function enables healthy yoghurt to be prepared at home. Automatic temperature and time settings provide optimal conditions that create homemade yoghurt in around 4 hours.



**BO747ST**  
Built-in oven



- + Colour: Reflective grey
- + Handle colour: Colour of brushed stainless steel
- + Control panel material: Glass
- + GentleClose door hinge

**Efficiency**

- + Multisystem oven BigSpace - 75 l
- + SuperSize baking area
- + HomeMADE® modelled on traditional wood-fired bread oven
- + PerfectGrill

**Control**

- + Electronic control + Knob shape: Ergonomic knobs + IconTouch

**Heating types**



**Features**

- + Illumination
- + Baking on different levels at the same time
- + MultiFlow 360°

**Equipment**

- + 1 deep enamelled baking pan
- + 1 shallow enamelled baking pan
- + Wire shelf
- + MeatProbe option
- + Oven guides: Fully extendable telescopic guides on three levels

**Safety**

- + Thermoelectric fuse
- + Dynamic oven cooling plus - DC+
- + Triple glazed oven door with double heat deflector (UltraCoolDoor)

**EasyCleaning**

- + AquaClean function
- + SilverMatte
- + Smooth oven door surface

**Technical data**

- + Energy consumption: **0,71 kWh** (venting), **0,94 kWh** (conventional)
- + Connected load: **3400 W**
- + Product dimensions (HxWxD): **59,5 x 59,5 x 54,6 cm**
- + Niche dimensions (HxWxD): **59 x 56 x 55 cm**



**BO637ST**  
Built-in oven



- + Colour: Reflective grey
- + Handle colour: Colour of brushed stainless steel
- + Control panel material: Glass
- + GentleClose door hinge

**Efficiency**

- + Multisystem oven BigSpace - 65 l
- + SuperSize baking area
- + Surface of the largest baking pan: 1316 cm²
- + HomeMADE® modelled on traditional wood-fired bread oven
- + PerfectGrill

**Control**

- + Mechanic temperature control + Knob shape: Ergonomic knobs + IconLed

**Heating types**



**Features**

- + Illumination
- + Baking on different levels at the same time

**Equipment**

- + 1 deep enamelled baking pan
- + 1 shallow enamelled baking pan
- + Wire shelf
- + Oven guides: Partially extendable telescopic guides on one level

**Safety**

- + Thermoelectric fuse
- + Dynamic oven cooling plus - DC+
- + Double glazed oven door with one heat deflector (CompactDoor)

**EasyCleaning**

- + AquaClean function
- + SilverMatte
- + Flat oven inner door glass surface: Removable

**Technical data**

- + Energy consumption: **0,85 kWh** (venting), **0,92 kWh** (conventional)
- + Connected load: **3300 W**
- + Product dimensions (HxWxD): **59,5 x 59,7 x 54,7 cm**
- + Niche dimensions min-max (HxWxD): **58,3-60 x 56-56,8 x 55 cm**





## BCM547ST

Combined compact microwave oven



- + Colour: Reflective grey
- + Handle colour: Colour of brushed stainless steel
- + Control panel material: Glass
- + GentleClose door hinge

### Efficiency

- + Combined microwave oven - 50 l
- + SuperSize baking area
- + HomeMADE® modelled on traditional wood-fired bread oven
- + Microwave power: 1000 W

### Control

- + Electronic control + Knob shape: Ergonomic knobs + IconTouch

### Heating types



### Features

- + MultiUse
- + Inverter technology
- + Stirrer technology
- + Illumination
- + Baking on different levels at the same time
- + MultiFlow 360°

### Equipment

- + 1 shallow enamelled baking pan
- + 1 glass baking pan
- + Wire shelf
- + Oven guides: 1x wire guides

### Safety

- + Thermoelectric fuse
- + Dynamic oven cooling plus - DC+
- + Triple glazing with a protective grid

### EasyCleaning

- + SilverMatte
- + Smooth oven door surface

### Technical data

- + Connected load: **3000 W**
- + Product dimensions (HxWxD): **45,5 x 59,5 x 54,6 cm**
- + Niche dimensions (HxWxD): **45 x 56 x 55 cm**



## BM251ST

Built-in microwave oven



- + Colour: Reflective grey
- + Front panel material: Glass + Door material: Glass
- + Stainless steel oven interior
- + Door opening: Left door opening + Door open type: On touch
- + Oven doors: Double-glazed oven door

### Efficiency

- + Oven volume: 25 l
- + Microwave power: 900 W
- + Power of upper infra heater: 1000 W
- + Number of infra heaters: 1
- + Technology of producing microwaves: Standard technology (HVT)
- + Type of microwave distribution: Rotating plate

### Control

- + Electronic control
- + Input type: Touch control
- + Type of display: LCD display

### Heating types



- + Combined heating: Microwaves + grill

### Features

- + AUTO menu
- + Time display

### Safety

- + Door safety bolt

### Equipment

- + Rotating glass plate
- + Rotating grid

### Technical data

- + Connected load: **1450 W**
- + Frame dimensions: **595 x 390 x 20 mm**
- + Product dimensions (HxWxD): **38,8 x 59,5 x 41 cm**
- + Niche dimensions (HxWxD): **38 x 56,7 x 43 cm**



## WD14ST

Warming drawer



+ Colour: Reflective grey

### Efficiency

- + Number of servings: Set for 6 persons or 20 dishes in diameter 28 cm or 80 coffee cups or 40 tea cups
- + Capacity: 6 servings

### Functions / Operating

- + Warming of plates
- + Warming of cups
- + Heat preservation
- + Defrosting of food
- + Yoghurt
- + Manual setting of temperature and timer

### Features

- + Air vented circulation
- + Time setting: Stop
- + Control: Touch control
- + Variable temperature
- + Cold front
- + Drawer bottom: Glass

### Technical data

- + Usable volume: 19,8 l
- + Temperature range: 40 – 80 °C
- + Timer range: 60 – 240 min
- + Connection rating: 410 W
- + Product dimensions (HxWxD): **14 x 59,5 x 56 cm**
- + Niche dimensions min-max (HxWxD): **14 x 56,4-57 x 55 cm**





## IS756ST

Induction hob



- + Colour : Black / Chrome
- + Hob frame
- + Aluminium

### Control

- + SmartControl
- + Timer function

### Features

- + StayWarm function
- + PowerBoost function
- + XpandZone

### Cooking surface

- + 4 induction heating zones
  - Left front: Ø 20x20 cm, 1,8/3 kW,
  - Right front: Ø 20x20 cm, 1,8/3 kW,
  - Left behind: Ø 20x20 cm, 1,8/3 kW,
  - Right behind: Ø 20x20 cm, 1,8/3 kW

### Safety and durability

- + Safety control hob lock
- + ChildLock

### Technical data

- + Connected load: **7200 W**
- + Product dimensions (HxWxD): **6 x 75 x 51 cm**
- + Niche dimensions (HxWxD): **5 x 56 x 49 cm**

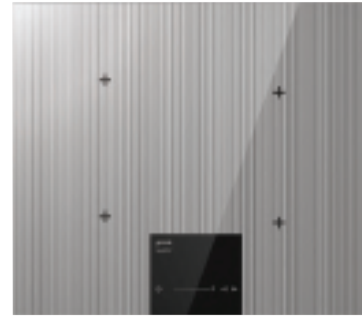

## IS634ST

Induction hob



- + Colour: Chrome / Black
- + Aluminium hob edges

### Control

- + SliderTouch, control at your fingertips
- + Timer function

### Features

- + StopGo function
- + PowerBoost function
- + AllBoost
- + Silent operation SuperSilent

### Cooking surface

- + 4 induction heating zones
  - Left front: Ø 18,5 cm, 1,4/2 kW
  - Right front: Ø 16,5 cm, 1,2/1,4 kW
  - Left behind: Ø 16,5 cm, 1,2/1,4 kW
  - Right behind: Ø 20,5 cm, 2/2,3 kW

### Safety and durability

- + Residual heat indicator
- + ChildLock

### Technical data

- + Connected load: **7100 W**
- + Product dimensions (HxWxD): **6,2 x 59,5 x 52 cm**
- + Niche dimensions (HxWxD): **7 x 55,8-56 x 49 cm**



## WHI 941 ST

Wall mounted cooker hood



- + Venting with air extraction or recirculation / Material of housing/chimney
- + Colour of housing/chimney: Stainless steel and glass / Stainless steel
- + Stainless steel and glass / Stainless steel

### Efficiency

- + Maximum extraction rate by extraction operation: 1000 m<sup>3</sup>/h
- + Venting tube diameter: 15 cm
- + The capacity of ventilator
- + Number of PowerBoost functions: 2

### Control

- + AdaptTech: Automatic fan operation
- + Electronic control
- + Control setting: Touch control
- + Timer function
- + Number of speed positions: 3

### Features

- + TouchFree Inox
- + Constant ventilation ReFresh
- + Lamp type: Led stripe
- + On/off light switch
- + Number of lights: 1
- + Air purifying function
- + Power of lights: 6 W
- + Perimetric suction

### Equipment

- + Filter material: Aluminium
- + Grease filter indicator
- + Washable grease filter
- + Number of motors: 1
- + Motor type: Capacitor motor
- + No return airflow flap: 150 mm

### Technical data

- + Noise level (max.): **59 dB(A)re 1 pW**
- + Product dimensions (WxD): **90 x 47 cm**
- + Height: **450 mm**
- + Min. height of the chimney: **995 mm**
- + Max. height of the chimney: **1275 mm**
- + Annual energy consumption: **50,8 kWh**



## WHI 641 ST

Wall mounted cooker hood



- + Venting with air extraction or recirculation / Material of housing/chimney
- + Colour of housing/chimney: Stainless steel and glass / Stainless steel
- + Stainless steel and glass / Stainless steel

### Efficiency

- + Maximum extraction rate by extraction operation: 1000 m<sup>3</sup>/h
- + Venting tube diameter: 15 cm
- + The capacity of ventilator
- + Number of PowerBoost functions: 2

### Control

- + AdaptTech: Automatic fan operation
- + Electronic control
- + Control setting: Touch control
- + Timer function
- + Number of speed positions: 3

### Features

- + TouchFree Inox
- + Constant ventilation ReFresh
- + Lamp type: Led stripe
- + On/off light switch
- + Number of lights: 1
- + Air purifying function
- + Power of lights: 6 W
- + Perimetric suction

### Equipment

- + Filter material: Aluminium
- + Grease filter indicator
- + Washable grease filter
- + Number of motors: 1
- + Motor type: Capacitor motor
- + No return airflow flap: 150 mm

### Technical data

- + Noise level (max.): **59 dB(A)re 1 pW**
- + Product dimensions (WxD): **60 x 47 cm**
- + Height: **450 mm**
- + Min. height of the chimney: **995 mm**
- + Max. height of the chimney: **1275 mm**
- + Annual energy consumption: **50,8 kWh**





**DPR-ST**  
Decor panel for built-in refrigerator

59,5 cm  
179 cm

- + Control panel material: Glass
- + Handle colour: Colour of brushed stainless steel

**Technical data**  
+ Product dimensions (HxWxD): **179 x 59,5 x 5,7 cm**

Combinable with  
Built-in integrated fridge freezer :  
NRKI2181A1

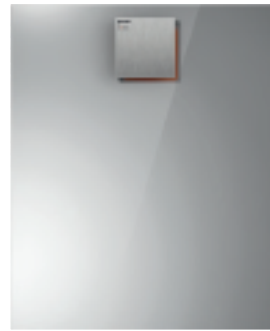

**DFD70ST**  
Dishwasher decor panel

59,6 cm  
70 cm

- + Control panel material: Glass
- + Handle colour: Colour of brushed stainless steel

**Technical data**  
+ Product dimensions (HxWxD):  
**70 x 59,5 x 1,8 cm**

Combinable with  
Built-in dishwasher :  
GV64161



**DFD72ST**  
Dishwasher decor panel

59,6 cm  
72 cm

- + Control panel material: Glass
- + Handle colour: Colour of brushed stainless steel

**Technical data**  
+ Product dimensions (HxWxD):  
**71.6 x 59,5 x 1,8 cm**

Combinable with  
Built-in dishwasher :  
GV66260



Oven

BO747ST

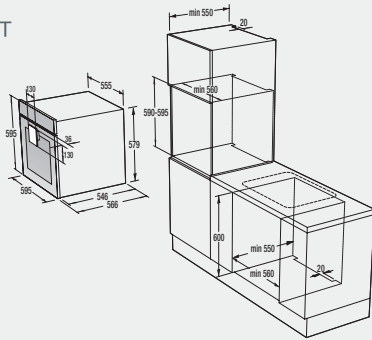

Oven

BO637ST

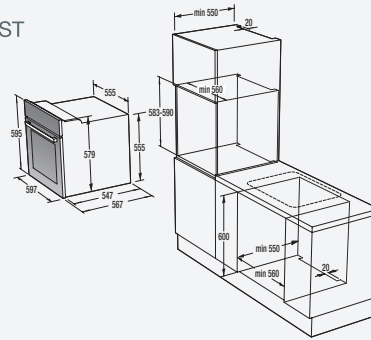

Combined compact microwave oven

BCM547ST

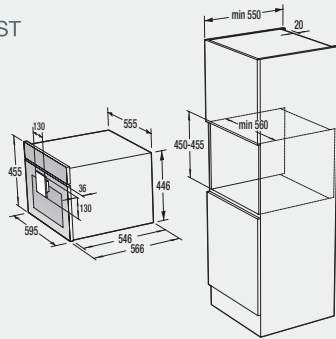

Built-in microwave oven

BM251ST

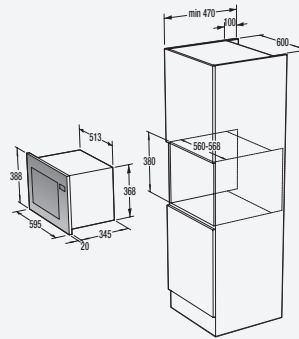

Induction hob

IS756ST

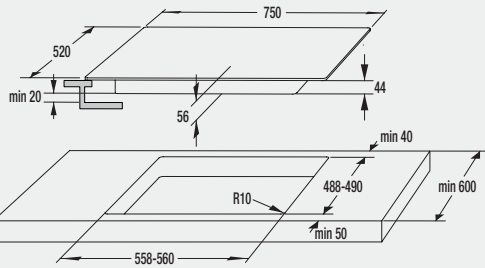

Induction hob

IS634ST

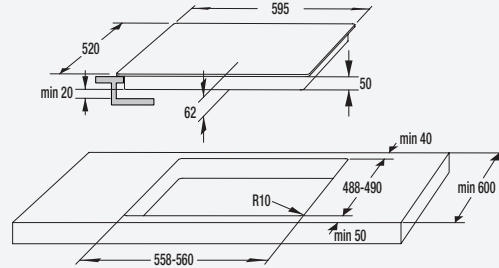

Wall mounted cooker hood

WHI941ST

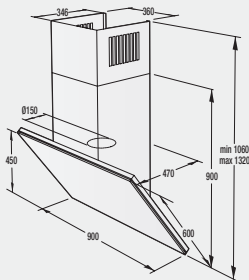

Wall mounted cooker hood

WHI641ST

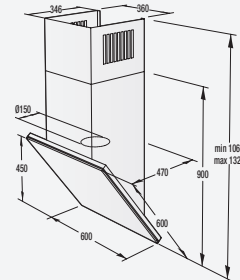



## Warming drawer

WD14ST

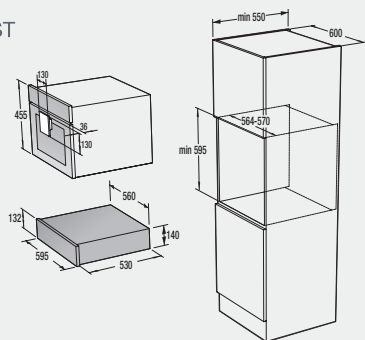

## Decor panel for refrigerator

DPR-ST

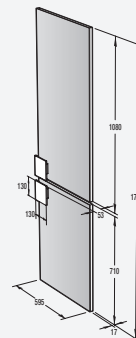

## Decor panel for diswasher

DFD70ST

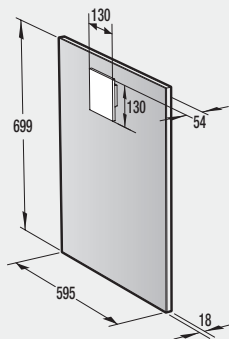

## Decor panel for diswasher

DFD72ST

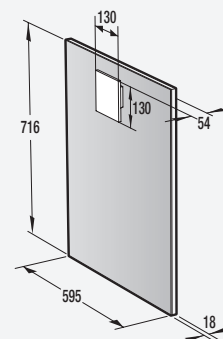







### Important Notes:

- Terms & conditions and Other areas not covered by the warranty are stated in the warranty card.
- The Warranty Terms and Conditions shall be effective for the products sold by Gorenje AEC Co., Ltd. or its authorized distributor only.
- All MDA Gorenje products are standard warranty for 2 years, covering spare parts and labor cost.
- All prices exclude installation and delivery fees.
- All prices, pictures, colours, models, diagrams and specifications are for reference purposes only and subject to change without prior notice.
- Appliances are available while stock lasts.
- Company will not responsible for any errors caused by printing process.
- We bear no liability for any misprint or other errors that might occur in the production of the catalogue.
- For Service Enquiry, please contact Gorenje Aftersales telephone: 02 631-1675 (Monday – Friday during 08:30 – 17:30)
- For more information, please contact gorenje or visit our website [www.gorenje.com](http://www.gorenje.com)



**gorenje**

BY

**S+ARCK®**

[www.gorenje.com](http://www.gorenje.com)

[www.parsital.com](http://www.parsital.com)

**Gorenje AEC Co., Ltd.**

Regional Head Office  
Liberty Square Bldg., 12th floor, unit 1206  
287 Silom Road Bangrak, Bangkok, Thailand 10500

+662 631-1675 ✉ [info.aec@gorenje.com](mailto:info.aec@gorenje.com)  [gorenje.thailand](https://www.facebook.com/gorenje.thailand)

**Australia + Belgium + China + Denmark + France + Germany + HongKong + Japan + Korea + Russia + Switzerland + Taiwan + Thailand + United Kingdom**