

Master Catalogue



Electronic Tapware since 1978



Introduction	page	4
Integrated Solutions for Bathroom Furnishings		12
Electronic Tapware	Top Collection	20
	All-in-One	36
	Compact	52
	with Long Spout	76
	with Extension	88
	Wall Mounted	92
	Kitchen	108
Washbasins for Public Washrooms		116
Electronic Soap Dispensers		120
Electronic Hand Dryers		130
Automatic Hair Dryers		138
Electronic Showers		142
Electronic Urinals		154
Electronic WCs		168
DMP Furnishings		182
Techno-Structures for Drywall		186
Product Index		188

Technical drawing dimensions are expressed in millimetres.



From idea to market

In 1978 DMP Electronics created the first electronic tap. Nothing like it has ever been seen before: it was a simple and ingenious idea, intended to change the daily habits and routines of many people throughout the world. Today, like then, we strive to learn, to challenge ourselves, to grow and to improve. We like the idea of being able to introduce infinite solutions to the market to save water through safe, efficient and reliable products manufactured with passion, skill and teamwork.



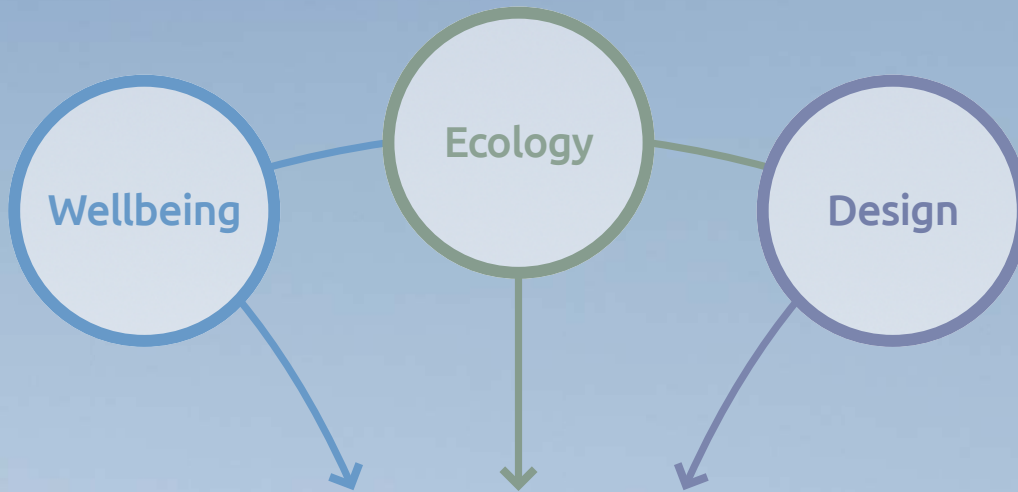

- Electronic Tapware
- Washbasins for Public Washrooms
- Electronic Showers
- Automatic Hair Dryers
- Electronic Dispensers
- Electronic Hand Dryers
- Electronic Urinals
- Electronic WCs



Ecological Advantage

Our water saving solutions protect water resources and ecological assets while guaranteeing immediate benefits on your bill, at home and in public establishments. In our example we took into account a restaurant that serves 40 people and we assessed two water consumption hypotheses: in the first case, normal taps with knobs were installed; in the second, DMP electronic taps were installed

Manual Tap

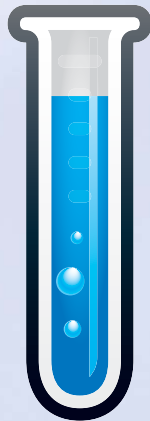

**178 liters
per day**

DMP Tap

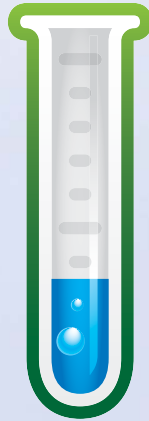

**43 liters
per day**



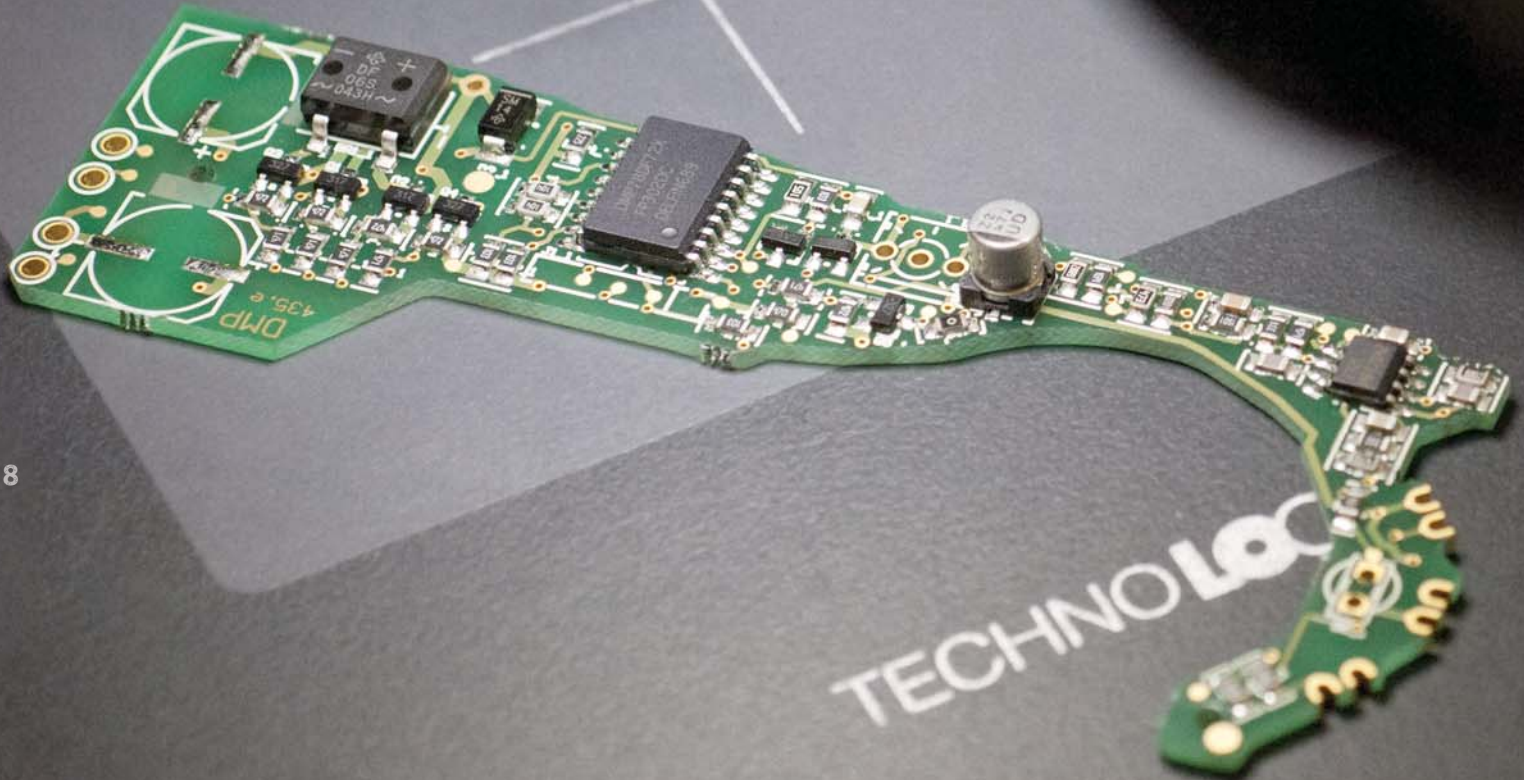

Technological Leadership

Our entire product supply chain is fully developed in-house, from design to prototypes, from production to testing and the guarantee of DMP Electronics brand reliability. After an initial phase dedicated to market research, we develop the design through engineering and design processed to obtain the end product. Quality testing begins from the prototype phase.

Some examples of DMP total quality:

100% Italian design

100% Italian technology

100% In-house design

100% Tested products

100% Non-toxic materials

100% EC and HACCP certified products

100% DMP original solenoid valves

100% In-house designed electronics

100% Made in Italy



Services and Partnerships

DMP Electronics covers more than 40 countries with a network of Wholesalers and Dealers, with whom we have established a partnership based on shared values and goals: to provide customers with services and solutions for all their needs.



Saniflush
Electronic Urinals
page 162



Turbo
Electronic Hand Dryer
page 130



Washbasin
DMP Furnishings Series
page 182



Eco Plus
Electronic Tap
page 64

Sanisoap Inox
Soap Dispenser
page 120



Sanisoap Abs
Soap Dispenser
page 124



Class Abs
Electronic Tap
page 40

White Kit



Aria
Electronic Hand Dryer
page 134

Bathroom Furniture
DMP Furnishings Series
page 182

Dikaflush
Electronic WCs
page 168

Panel Walls
DMP Furnishings Series
page 182



Splash
Electronic Shower
page 142



Electronic Tube Bidet

Electronic Tap for Bidet
page 75



Shower Tube
recessed, with mixer
page 75



Tube Plus RZ
Electronic Tap with Extension
page 90





Recommended for:



Hospitality



Residential



Institutions



Catering



Overview:

A real technological jewel must be easy to use, reliable in its functions and flexible in adapting to the different environments. MiniUno 40 is the synthesis of these features that make it a unique electronic tap in the sector. It is available with chrome or satin finish, with or without mixer, and can be powered by two 1.5V alkaline batteries or by a 5V safety transformer.

Features:

- DMP Infrared System photocell sensors, scratch proof and protected against calcium deposits
- Fully waterproof resined electronic circuit
- Chrome-plated brass body polished or satin finish
- The electronic, the batteries and the solenoid valve are in the tap body (all in one)
- MiniUno BT : installation with fast connection fittings 1/2 G (**FIG. 1**).
- Installation with recessed stainless steel box on all the other models (**FIG. 2**).
- Mounting at minimum 27 mm from the sink (**FIG. 3**)
- DMP software programmed microchip for perfect function control
- Optimized functions for a long life of the alkaline batteries
- Autonomy of the batteries: 4-year battery life with 200 activations per day
- Low battery warning: a led in the sensors blinking twice every six seconds indicates that the batteries still have approx. 3 months autonomy
- Batteries easy to change and readily available
- Fully waterproof battery case
- Function for flood and consumption protection: the DMP shut-off timer stops the water flow after 90 seconds of continuous use
- Optimized water consumption with limiter at

6 l/min. Optional: limiter at 3 l/min

- Solenoid valve with triple, stainless steel and anti-impurities filter

Technical Specifications:

- AA 1.5 V alkaline batteries
- Electronic circuit: 3 V, manufactured in compliance with CEI EN 55014-1/-2 (EMC) requirements
- Solenoid valve: 2 V
- Safety transformer: 230Vac - 5Vdc, IMQ approved and manufactured in compliance with CEI EN 61558-1/-2-6 requirements
- IP65 electrical part protection grade
- Adjustable sensors' range of action: 5 - 20 cm
- Non return valves (MiniUnoMix)
- Water pressure: 0.4 - 10 bar
- Pipe fittings: 1/2 G

Package Contents:

- Electronic tap MiniUno 40
- Recessed box with fast connection flexible hoses (MiniUnoMix)
- Instruction manual
- Battery case with 2 alkaline batteries
or
- DMP safety transformer

Installation with 1/2G quick connect coupling

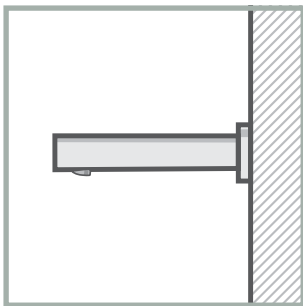

FIG. 1

The following models: MiniUno 40300 BT, MiniUno 40250 BT and MiniUno 40215 BT can be installed directly on the wall, on the 1/2G water inlet.

Installation WITH built-in box

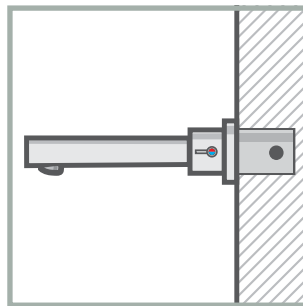

FIG. 2

All the other models on page 35 can anyway be installed directly onto the wall, with the only support of an extremely small stainless steel box (67mm deep).

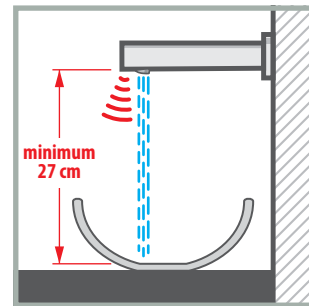

FIG. 3

In order to offer users the most comfortable experience, DMP recommends MiniUno 40 is installed at a minimum distance of 27cm from the bottom of the washbasin.

MiniUno 40300 BT



82986 Chrome
82988 Satin

For cold or pre-mixed water
Power: 2x1.5V AA alkaline batteries
Installation without case (FIG. 1) - 1 inlet: 1/2 G

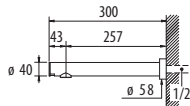

MiniUno 40312



22986 Chrome
22988 Satin

For cold or pre-mixed water
Power: 5 Vdc transformer
Installation with case (FIG. 2) - 1 inlet: 1/2 G

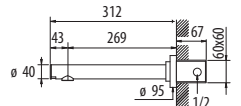

MiniUno 40250 BT



82956 Chrome
82958 Satin

For cold or pre-mixed water
Power: 2x1.5V AA alkaline batteries
Installation without case (FIG. 1) - 1 inlet: 1/2 G

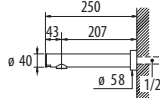

MiniUno 40262



22956 Chrome
22958 Satin

For cold or pre-mixed water
Power: 5 Vdc transformer
Installation with case (FIG. 2) - 1 inlet: 1/2 G

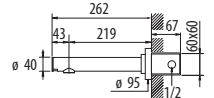

MiniUno 40215 BT



82926 Chrome
82928 Satin

For cold or pre-mixed water
Power: 2x1.5V AA alkaline batteries
Installation without case (FIG. 1) - 1 inlet: 1/2 G

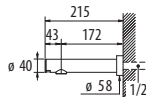

MiniUno 40227



22926 Chrome
22928 Satin

For cold or pre-mixed water
Power: 5 Vdc transformer
Installation with case (FIG. 2) - 1 inlet: 1/2 G

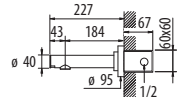

MiniUnoMix 40300 BT



85156 Chrome
85158 Satin

With built-in mixer
Power: 2x1.5V AA alkaline batteries
Installation with case (FIG. 2) - 2 inlets: 1/2 G

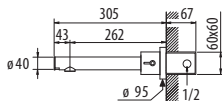

MiniUnoMix 40300



25156 Chrome
25158 Satin

With built-in mixer
Power: 5 Vdc transformer
Installation with case (FIG. 2) - 2 inlets: 1/2 G

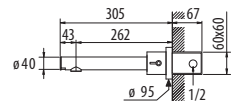

MiniUnoMix 40270 BT



85126 Chrome
85128 Satin

With built-in mixer
Power: 2x1.5V AA alkaline batteries
Installation with case (FIG. 2) - 2 inlets: 1/2 G

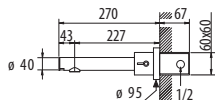

MiniUnoMix 40270



25126 Chrome
25128 Satin

With built-in mixer
Power: 5 Vdc transformer
Installation with case (FIG. 2) - 2 inlets: 1/2 G

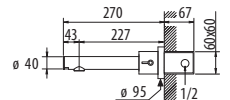

MiniUnoMix 40240



25116 Chrome
25118 Satin

With built-in mixer
Power: 5 Vdc transformer
Installation with case (FIG. 2) - 2 inlets: 1/2 G

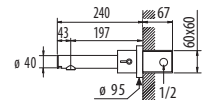

Availability: 6/10 business days

Transformers, batteries and accessories are all included in the price.

Certifications: EMC Safety Transformer (230Vac/5Vdc)

The recessed boxes can be supplied in advance, on demand.

Overview:

With its three-photocell sensors, Class Metal is a wide range electronic tap with 120° reading sensors, studied and designed to detect hands also laterally. It has an all-in-one structure: all the electronic and mechanical parts are included in the body, with great advantages in terms of easiness, of installation and maintenance.

Versions Available:

With built-in mixer.

For cold or pre-mixed water.

With mixer in the tap body.

With under washbasin mixer.

Power Available:

3 AA 1.5 V alkaline batteries.

230Vac - 5Vdc safety transformer.

Pluses:

Photocell activation.

Water saving up to 80%.

Hygiene and wellbeing.

Easy to use.

Long battery life.

Three-photocells.

100% Made in Italy.

Recommended for:

Public



Institutions



Catering



Health



Industry



Features:

- DMP Infrared System three-photocell sensors, scratch proof and protected against calcium deposits (**FIG. 1**)
- Fully waterproof resined electronic circuit
- Chrome-plated metal body, constructed with specific vandal-proof criteria
- Stainless steel installation kit
- DMP software programmed microchip for perfect function control
- Optimized functions for a long life of the alkaline batteries
- Autonomy of the batteries: 4-year battery life with 200 activations per day
- Batteries easy to change and readily available (**FIG. 2**)
- Low battery warning: a led in the sensors blinking twice every six seconds indicates that the batteries still have approx. 3 months autonomy
- Fully waterproof battery case
- Function for flood and consumption protection (**FIG. 3**)
- Optimized water consumption with limiter at 6 l/min. Optional : limiter at 3 l/min
- Solenoid valve with triple, stainless steel and anti-impurities filter
- Shut-off valves inside the recessed box, equipped with stainless steel, anti-impurities 0.2 mm mesh filters

Technical Specifications:

- AA 1.5 V alkaline batteries
- Electronic circuit: 4.5 V, manufactured in compliance with CEI EN 55014-1/-2 (EMC) requirements
- Solenoid valve: 3 V
- Safety transformer: 230Vac - 5Vdc, IMQ approved and manufactured in compliance with CEI EN 61558-1/-2-6 requirements
- IP65 electrical part protection grade
- Adjustable sensors' range of action: 12 - 35 cm
- Stop taps with non-return valves
- Water pressure: 0.4 - 10 bar
- Pipe fittings: 1/2 G

Package Contents:

- Class Metal electronic tap
- DMP fast connection flexible hoses
- DMP original stop taps
- Installation kit
- Instruction manual
- Battery case with 3 alkaline batteries
or
- DMP safety transformer

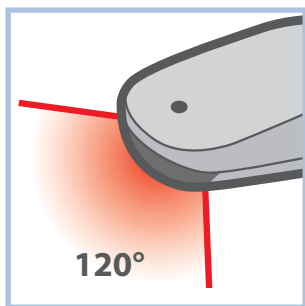

FIG. 1

Class is the only three-photocell electronic tap, equipped with an ample 120 degree range of action that translates into highly comfortable use.

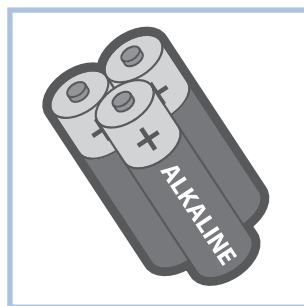

FIG. 2

Class Metal uses batteries that are readily available: in supermarkets as well as in corner shops. Easy to find, long-lasting.



FIG. 3

The shut-off timer is a flood protection device that stops the water flow after one and a half minutes of continuous use. Maximum safety.

Class 20 Metal BT



- 82206 Chrome**
- 82203 White**
- 82213 Satin**

With built-in mixer
 Power: 3x1.5V AA alkaline batteries
 Package weight: Kg. 2.500
 Availability: 2 business days

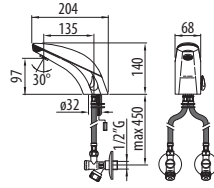

Class 20 Metal



- 22206 Chrome**
- 22203 White**
- 22213 Satin**

With built-in mixer
 Power: 5 Vdc transformer
 Package weight: Kg. 2.700
 Availability: 2 business days

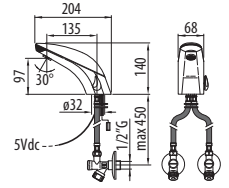

Class 10 Metal BT



- 82106 Chrome**
- 82103 White**
- 82113 Satin**

For cold or pre-mixed water
 Power: 3x1.5V AA alkaline batteries
 Package weight: Kg. 2.200
 Availability: 2 business days

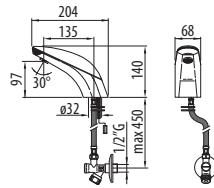

Class 10 Metal



- 22106 Chrome**
- 22103 White**
- 22113 Satin**

For cold or pre-mixed water
 Power: 5 Vdc transformer
 Package weight: Kg. 2.400
 Availability: 2 business days

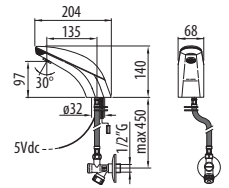

Class 30 Metal BT



- 82306 Chrome**
- 82303 White**
- 82313 Satin**

With under washbasin mixer *
 Power: 3x1.5V AA alkaline batteries
 Package weight: Kg. 2.700
 Availability: 5 business days

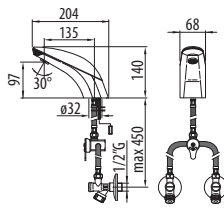

Class 30 Metal



- 22306 Chrome**
- 22303 White**
- 22313 Satin**

With under washbasin mixer *
 Power: 5 Vdc transformer
 Package weight: Kg. 2.900
 Availability: 5 business days

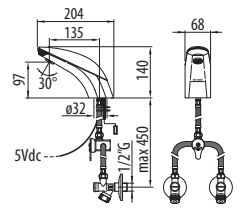

* The mixer handle can be blocked once the temperature is set.

* The mixer handle can be blocked once the temperature is set.

Class 20 TL Metal BT



- 82206.TL Chrome**
- 82203.TL White**
- 82213.TL Satin**

With internal mixer *
 Power: 3x1.5V AA alkaline batteries
 Package weight: Kg. 2.500
 Availability: 5 business days

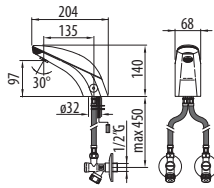

Class 20 TL Metal



- 22206.TL Chrome**
- 22203.TL White**
- 22213.TL Satin**

With internal mixer *
 Power: 5 Vdc transformer
 Package weight: Kg. 2.700
 Availability: 5 business days

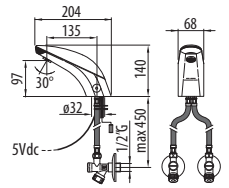

* Temperature adjustment on tap, with vandal-proof safety stopper.

* Temperature adjustment on tap, with vandal-proof safety stopper.

Transformers, batteries, flexible hoses, stop taps and accessories are all included in the price.

Certifications: **CE EMC ACS HACCP** **PG** Safety Transformer **TM** (230Vac/5Vdc)

Overview:

With its three-photocell sensors, Class Abs is a wide range electronic tap with 120° reading sensors, studied and designed to detect hands also laterally. It has an all-in-one structure: all the electronic and mechanical parts are included in the body, with great advantages in terms of easiness of installation and maintenance.

Versions Available:

With built-in mixer.

For cold or pre-mixed water.

With mixer in the tap body.

With under washbasin mixer

Power Available:

3 AA 1.5 V alkaline batteries.

230Vac - 5Vdc safety transformer.

Pluses:

Photocell activation.

Water saving up to 80%.

Hygiene and wellbeing.

Easy to use.

Long battery life.

Three-photocells.

100% Made in Italy.

Recommended for:

Public



Institutions



Catering



Health



Industry



DMP recommends **Class Abs** in combination with the electronic soap dispenser **Sanisoap Abs** (page 124) and with the electronic hand dryer **Aria** (page 128). The three articles form the **White Kit** (pages 14 and 15)

Features:

- DMP Infrared System three-photocell sensors, scratch proof and protected against calcium deposits (**FIG. 1**)
- Fully waterproof resined electronic circuit
- Body made of shockproof ABS, chrome or white
- Stainless steel installation kit
- DMP software programmed microchip for perfect function control
- Optimized functions for a long life of the alkaline batteries
- Autonomy of the batteries: 4-year battery life with 200 activations per day
- Batteries easy to change and readily available (**FIG. 2**)
- Low battery warning led (**FIG. 3**)
- Fully waterproof battery case
- Function for flood and consumption protection: the DMP shut-off timer stops the water flow after 90 seconds of continuous use
- Optimized water consumption with limiter at 6 l/min. Optional: limiter at 3 l/min
- Solenoid valve with triple, stainless steel and anti-impurities filter
- Shut-off valves inside the recessed box, equipped with stainless steel, anti-impurities 0.2 mm mesh filters

Technical Specifications:

- AA 1.5 V alkaline batteries
- Electronic circuit: 4.5 V, manufactured in compliance with CEI EN 55014-1/-2 (EMC) requirements
- Solenoid valve: 3 V
- Safety transformer: 230Vac - 5Vdc, IMQ approved and manufactured in compliance with CEI EN 61558-1/-2-6 requirements
- IP65 electrical part protection grade
- Adjustable sensors' range of action: 12 - 35 cm
- Stop taps with non-return valves
- Water pressure: 0.4 - 10 bar
- Pipe fittings: 1/2 G

Package Contents:

- Electronic tap Class Abs
- DMP fast connection flexible hoses
- DMP original stop taps
- Installation kit
- Instruction manual
- Battery case with 3 alkaline batteries
or
- DMP safety transformer

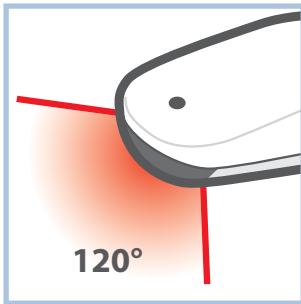

FIG. 1

Class Abs is the only three-photocell electronic tap, equipped with an ample 120 degree range of action that translates into highly comfortable use.

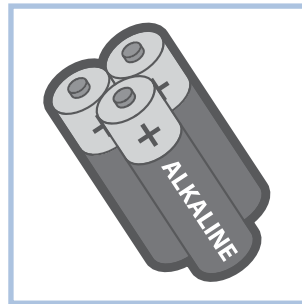

FIG. 2

Class Abs uses batteries that are readily available: in supermarkets as well as in corner shops. Easy to find, long-lasting.

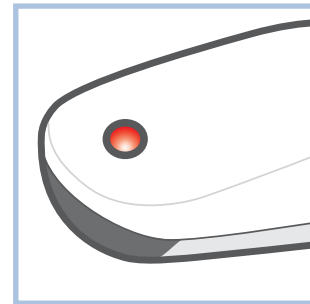

FIG. 3

When batteries are nearly exhausted, the red LED starts flashing twice every 6 seconds, warning that batteries have still got about 3 months' life.

Class 20 Abs BT



83206 Chrome
83203 White

With built-in mixer
Power: 3x1.5V AA alkaline batteries
Package weight: Kg. 1.700
Availability: 2 business days

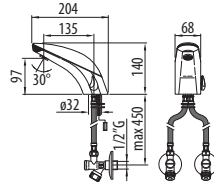

Class 20 Abs



23206 Chrome
23203 White

With built-in mixer
Power: 5 Vdc transformer
Package weight: Kg. 1.900
Availability: 2 business days

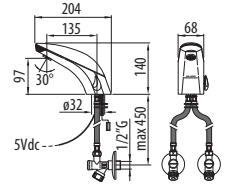

Class 10 Abs BT



83106 Chrome
83103 White

For cold or pre-mixed water
Power: 3x1.5V AA alkaline batteries
Package weight: Kg. 1.450
Availability: 2 business days

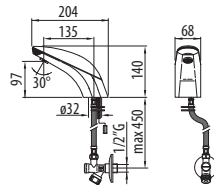

Class 10 Abs



23106 Chrome
23103 White

For cold or pre-mixed water
Power: 5 Vdc transformer
Package weight: Kg. 1.650
Availability: 2 business days

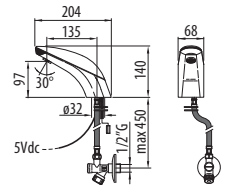

Class 30 Abs BT



83306 Chrome
83303 White

With under washbasin mixer *
Power: 3x1.5V AA alkaline batteries
Package weight: Kg. 1.900
Availability: 5 business days

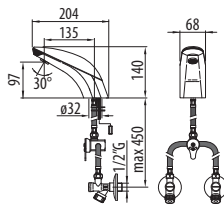

Class 30 Abs



23306 Chrome
23303 White

With under washbasin mixer *
Power: 5 Vdc transformer
Package weight: Kg. 2.100
Availability: 5 business days

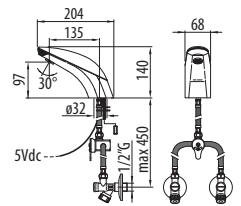

* The mixer handle can be blocked once the temperature is set.

* The mixer handle can be blocked once the temperature is set.

Class 20 TL Abs BT



83206.TL Chrome
83203.TL White

With internal mixer *
Power: 3x1.5V AA alkaline batteries
Package weight: Kg. 1.650
Availability: 5 business days

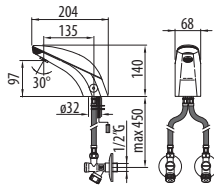

Class 20 TL Abs



23206.TL Chrome
23203.TL White

With internal mixer *
Power: 5 Vdc transformer
Package weight: Kg. 1.850
Availability: 5 business days

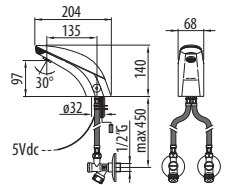

* Temperature adjustment on tap, with vandal-proof safety stopper.

* Temperature adjustment on tap, with vandal-proof safety stopper.

Transformers, batteries, flexible hoses, stop taps and accessories are all included in the price.

Certifications: **CE EMC ACS HACCP** **PG** Safety Transformer **TM** (230Vac/5Vdc)

Overview:

Minimal in its shape, super-technological in its functions. Cento Tap is a tap that surprises you for its strong but elegant line. But what makes it unique is the electronics, all inside it, that transforms it into a high technology furnishing element that can guarantee immediate and substantial water savings. It is available in two versions.

Versions Available:

With built-in mixer.

For cold or pre-mixed water.

With under washbasin mixer.

(all available in two heights and lengths)

Power Available:

2 AA 1.5 V alkaline batteries.

230Vac - 5Vdc safety transformer.

Pluses:

Photocell activation.

Water saving up to 80%.

Hygiene and wellbeing.

Easy to use.

Long battery life.

100% Made in Italy.

Recommended for:

Public



Catering



Institutions



Health



Features:

- DMP Infrared System photocell sensors, scratch proof and protected against calcium deposits
- Fully waterproof resined electronic circuit (**FIG. 1**)
- Chrome-plated brass body $\varnothing 40$ mm, with 2 different heights spout, constructed with specific vandal-proof criteria
- Spout lengths: 180 mm and 130 mm (**FIG. 2**)
- Stainless steel installation kit
- DMP software programmed microchip for perfect function control
- Optimized functions for a long life of the alkaline batteries
- Autonomy of the batteries: 4-year battery life with 200 activations per day
- Batteries easy to change and readily available (**FIG. 3**)
- Fully waterproof battery case
- Low battery warning: a led in the sensors blinking twice every six seconds indicates that the batteries still have approx. 3 months autonomy
- Function for flood and consumption protection: the DMP shut-off timer stops the water flow after 90 seconds of continuous use
- Optimized water consumption with limiter at 6 l/min. Optional: limiter at 3 l/min
- Solenoid valve with triple, stainless steel and anti-impurities filter

- Shut-off valves inside the recessed box, equipped with stainless steel, anti-impurities 0.2 mm mesh filters

Technical Specifications:

- AA 1.5 V alkaline batteries
- Electronic circuit: 4.5 V, manufactured in compliance with CEI EN 55014-1/-2 (EMC) requirements
- Solenoid valve: 3 V
- Safety transformer: 230Vac - 5Vdc, IMQ approved and manufactured in compliance with CEI EN 61558-1/-2-6 requirements
- IP65 electrical part protection grade
- Adjustable sensors' range of action: 8 - 35 cm
- Stop taps with non-return valves
- Water pressure: 0.4 - 10 bar
- Pipe fittings: 1/2 G

Package Contents:

- Electronic tap Cento Tap
- DMP fast connection flexible hoses
- DMP original stop taps
- Installation kit
- Instruction manual
- Battery case with 2 alkaline batteries
or
- DMP safety transformer

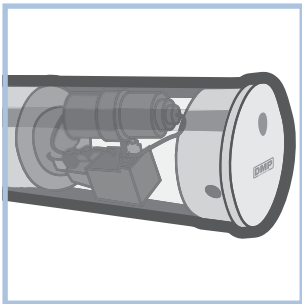

FIG. 1

Cento Tap is designed with an all-in-one structure holding and protecting the electronic circuit, solenoid valve and waterproof battery container.

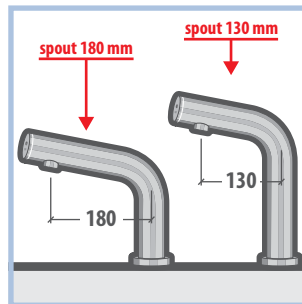

FIG. 2

According to the various design requirements, Cento Tap is available in two spout lengths and heights, to suit most washbasins currently on the market.

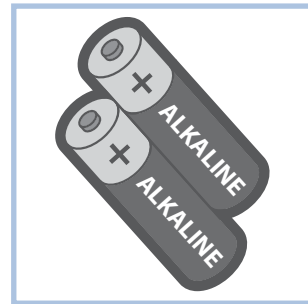

FIG. 3

Cento Tap uses batteries that are readily available: in hypermarkets as well as in corner shops. Easy to find, long-lasting.

CentoMix BT



86386 Centomix 180 BT
86306 Centomix 130 BT

Spout 180 mm
Spout 130 mm

Colour: chrome
 With built-in mixer
 Power: 2x1.5V AA alkaline batteries
 Package weight: Kg. 2.000 ÷ 2.100
 Availability: 10 business days
 Fixed spout

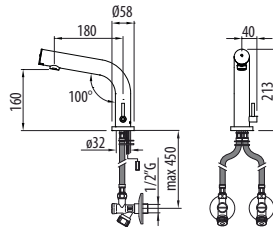

CentoMix



26386 Centomix 180
26306 Centomix 130

Spout 180 mm
Spout 130 mm

Colour: chrome
 With built-in mixer
 Power: 5 Vdc transformer
 Package weight: Kg. 2.100 ÷ 2.200
 Availability: 10 business days
 Fixed spout

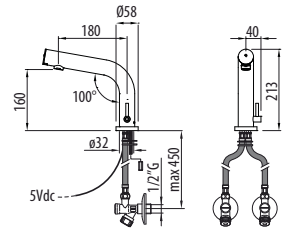

Cento Tap BT



86186 Centotap 180 BT
86106 Centotap 130 BT

Spout 180 mm
Spout 130 mm

Colour: chrome
 For cold or pre-mixed water
 Power: 2x1.5V AA alkaline batteries
 Package weight: Kg. 1.800 ÷ 1.900
 Availability: 10 business days
 Fixed spout

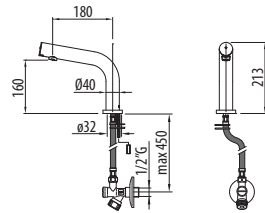

Cento Tap



26186 Centotap 180
26106 Centotap 130

Spout 180 mm
Spout 130 mm

Colour: chrome
 For cold or pre-mixed water
 Power: 5 Vdc transformer
 Package weight: Kg. 1.900 ÷ 2.000
 Availability: 10 business days
 Fixed spout

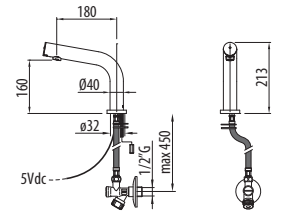

Cento Tap MS BT



86286 Centotap 180 MS BT
86206 Centotap 130 MS BT

Spout 180 mm
Spout 130 mm

Colour: chrome
 With under washbasin mixer*
 Power: 2x1.5V AA alkaline batteries
 Package weight: Kg. 2.200 ÷ 2.300
 Availability: 10 business days
 Fixed spout

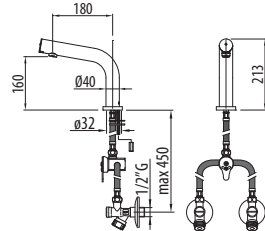

Cento Tap MS



26286 Centotap 180 MS
26206 Centotap 130 MS

Spout 180 mm
Spout 130 mm

Colour: chrome
 With under washbasin mixer*
 Power: 5 Vdc transformer
 Package weight: Kg. 2.300 ÷ 2.400
 Availability: 10 business days
 Fixed spout

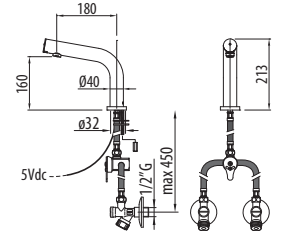

* The mixer handle can be blocked once the temperature is set.

* The mixer handle can be blocked once the temperature is set.

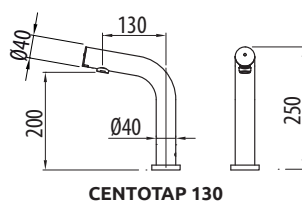
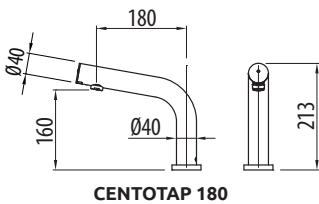

Transformers, batteries, flexible hoses, stop taps and accessories are all included in the price.

Certifications: **CE EMC HACCP** **PE** Safety Transformer **Ⓜ** (230Vac/5Vdc)

Overview:

Quary Tap is more than anything a new concept of electronic tap that finds its ideal enhancement in the Quary Soap electronic dispenser, identical in line but smaller in shape, that can be installed directly on the washbasin. Made entirely in chrome plated brass, Quary Tap has a small all-in-one body, with the electronics and solenoid valve inside it. The variety of available versions makes it a safe choice in all types of environment.

Versions Available:

With built-in mixer.

For cold or pre-mixed water.

With under washbasin mixer.

Power Available:

2 AA 1.5 V alkaline batteries.

230Vac - 5Vdc safety transformer.

Pluses:

Photocell activation.

Water saving up to 80%.

Hygiene and wellbeing.

Easy to use.

Long battery life.

Coordinated line with Quary Soap dispenser.

100% Made in Italy.

Recommended for:

Public



Query Tap
Electronic Tap

Query Soap
Soap Dispenser

DMP recommends **Query Tap** in combination with the electronic soap dispenser **Query Soap** (page 128)

Features:

- DMP Infrared System photocell sensors, scratch proof and protected against calcium deposits
- Fully waterproof resined electronic circuit (**FIG. 1**)
- Chrome-plated brass body ø40 mm, inclined 45° constructed with specific vandal-proof criteria
- Stainless steel installation kit
- DMP software programmed microchip for perfect function control
- Optimized functions for a long life of the alkaline batteries
- Autonomy of the batteries: 4-year battery life with 200 activations per day
- Batteries easy to change and readily available (**FIG. 2**)
- Fully waterproof battery case
- Low battery warning: a led in the sensors blinking twice every six seconds indicates that the batteries still have approx. 3 months autonomy
- Function for flood and consumption protection: the DMP shut-off timer stops the water flow after 90 seconds of continuous use
- Optimized water consumption with limiter at 6 l/min. Optional: limiter at 3 l/min
- Solenoid valve with triple, stainless steel and anti-impurities filter
- Shut-off valves inside the recessed box, equipped with stainless steel, anti-impurities 0.2 mm mesh filters

- Line and design coordinated with the electronic soap dispenser Quary Soap (**FIG. 3**)

Technical Specifications:

- AA 1.5 V alkaline batteries
- Electronic circuit: 4.5 V, manufactured in compliance with CEI EN 55014-1/-2 (EMC) requirements
- Solenoid valve: 3 V
- Safety transformer: 230Vac - 5Vdc, IMQ approved and manufactured in compliance with CEI EN 61558-1/-2-6 requirements
- IP65 electrical part protection grade
- Adjustable sensors' range of action: 8 - 35 cm
- Stop taps with non-return valves
- Water pressure: 0.4 - 10 bar
- Pipe fittings: 1/2 G

Package Contents:

- Electronic tap Quary Tap
- DMP fast connection flexible hoses
- DMP original stop taps
- Installation kit
- Instruction manual
- Battery case with 2 alkaline batteries
or
- DMP safety transformer

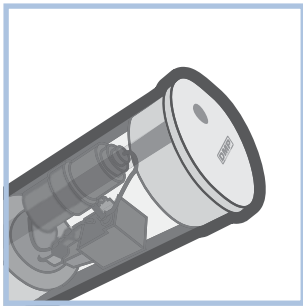

FIG. 1

Designed with an all-in-one structure, Quary Tap has all its great technology inside its body: electronic circuit, solenoid valve and waterproof battery box.

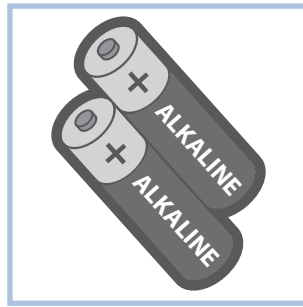

FIG. 2

Quary Tap uses batteries that are readily available: in supermarkets as well as in corner shops. Easy to find, long-lasting.

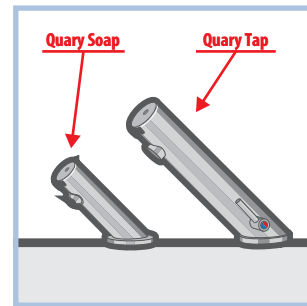

FIG. 3

Its ideal enhancement is Quary Soap, an electronic soap dispenser identical in line but smaller in size (see features and measurements on pages 128-129).

Query Mix BT

87606 Chrome

With built-in mixer
 Power: 2x1.5V AA alkaline batteries
 Package weight: Kg. 2.400
 Availability: 10 business days

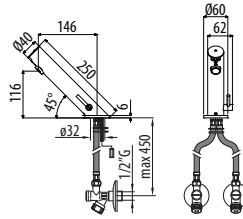

Query Mix

27606 Chrome

With built-in mixer
 Power: 5 Vdc transformer
 Package weight: Kg. 2.500
 Availability: 10 business days

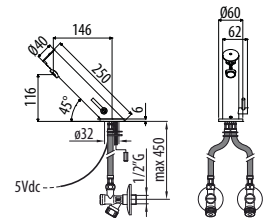

Query Tap BT

87506 Chrome

For cold or pre-mixed water
 Power: 2x1.5V AA alkaline batteries
 Package weight: Kg. 2.150
 Availability: 10 business days

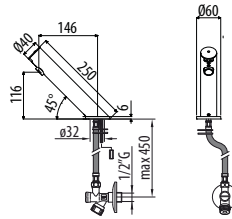

Query Tap

27506 Chrome

For cold or pre-mixed water
 Power: 5 Vdc transformer
 Package weight: Kg. 2.250
 Availability: 10 business days

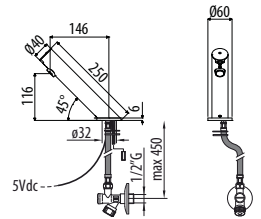

Query Tap MS BT

87906 Chrome

With under washbasin mixer*
 Power: 2x1.5V AA alkaline batteries
 Package weight: Kg. 2.600
 Availability: 10 business days

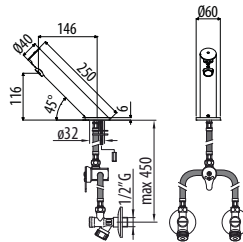

Query Tap MS

27906 Chrome

With under washbasin mixer*
 Power: 5 Vdc transformer
 Package weight: Kg. 2.700
 Availability: 10 business days

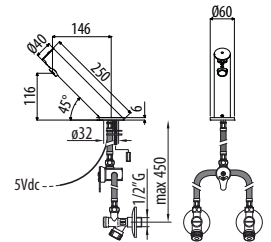

* The mixer handle can be blocked once the temperature is set.

* The mixer handle can be blocked once the temperature is set.

Transformers, batteries, flexible hoses, stop taps and accessories are all included in the price.

Certifications: **CE EMC HACCP** Safety Transformer (230Vac/5Vdc)

Overview:

Understatement and functionality combine to create Comfort, a complete and perfectly co-ordinated bathroom line. As well as the washbasin electronic tap, the kit includes also the manual single control taps for the bidet, bath and shower, all fitted with ceramic disk mixer.

Versions Available:

Comfort washbasin (electronic).

Comfort bidet (manual)

Comfort tub (manual)

Comfort shower (manual)

Power Available:

3 AA 1.5 V alkaline batteries.

230Vac - 5Vdc safety transformer.

Pluses:

Kit complete of taps for the bathroom.

Photocell activation. *

Water saving up to 80%. *

Hygiene and wellbeing. *

Easy to use. *

Long battery life. *

Button for continuous flow or stop flow mode. *

100% Made in Italy. *

Recommended for:

Residential



Hospitality

** Pluses refer to Comfort Washbasin*



Features:

- DMP photocell sensors, made of scratchproof and calcium resistant material
- Fully waterproof resined electronic circuit
- Chrome-plated brass body
- Stainless steel installation kit
- DMP software programmed microchip for perfect function control
- Optimized functions for a long life of the alkaline batteries
- Autonomy of the batteries: 4-year battery life with 200 activations per day
- Low battery warning: a led in the sensors blinking twice every six seconds indicates that the batteries still have approx. 3 months autonomy
- Batteries easy to change and readily available
- Fully waterproof battery case
- Continuous water flow mode (**FIG. 1**)
- Temporary tap stop function (**FIG. 2**)
- Function for flood and consumption protection (**FIG. 3**)
- Optimized water consumption with limiter at 6 l/min. Optional: limiter at 3 l/min
- Solenoid valve with triple anti-calcium filter
- Shut-off valves inside the recessed box, equipped with stainless steel, anti-calcium 0.2 mm mesh filters

Technical Specifications:

- AA 1.5 V alkaline batteries
- Electronic circuit: 4.5 V, manufactured in compliance with CEI EN 55014-1/-2 (EMC) requirements
- Solenoid valve: 3 V
- Safety transformer: 230Vac - 5Vdc, IMQ approved and manufactured in compliance with CEI EN 61558-1/-2-6 requirements
- IP65 electrical part protection grade
- Adjustable sensors' range of action: 8 - 35 cm
- Stop taps with non-return valves
- Water pressure: 0.4 - 10 bar
- Pipe fittings: 1/2 G

Package Contents:

- Electronic tap Comfort
- DMP fast connection flexible hoses
- DMP original stop taps
- Installation kit
- Instruction manual
- Battery case with 3 alkaline batteries
or
- DMP safety transformer

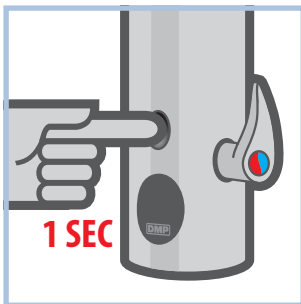

FIG. 1

Pressing the button for 1 second activates continuous flow mode. When pressing the button for 1 second again, the tap reverts to electronic mode.

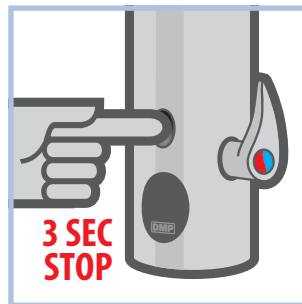

FIG. 2

Press and hold the button down for 3 seconds to activate stop mode, practical for washbasin cleaning. Press and hold down again for 3 seconds to restart.



FIG. 3

The shut-off timer is a flood protection device that stops the water flow after one and a half minutes of continuous use. Maximum safety.

Comfort Washbasin BT



78106 Chrome
Without pop up drain

78126 Chrome
With pop up drain

With built-in mixer
With multifunction button
Power: 3x1.5V AA alkaline batteries
Package weight: Kg. 2.900
Availability: 5 business days

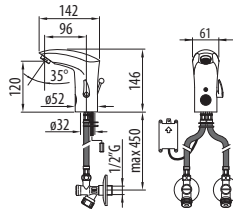

Comfort Washbasin



18106 Chrome
Without pop up drain

18126 Chrome
With pop up drain

With built-in mixer
With multifunction button
Power: 5 Vdc transformer
Package weight: Kg. 3.000
Availability: 5 business days

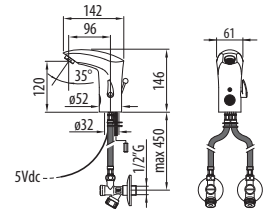

Comfort Bidet



18206 Chrome
Without pop up drain

18226 Chrome
With pop up drain

With ceramic disk mixer
Non electronic operation
Package weight: Kg. 2.700
Availability: 5 business days

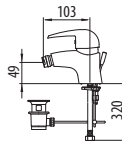

Comfort Tub



18306 Chrome

With ceramic disk mixer
Non electronic operation
With hand shower
Package weight: Kg. 2.800
Availability: 5 business days

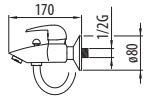

Comfort External Shower



18506 Chrome

With ceramic disk mixer
Non electronic operation
With hand shower
Package weight: Kg. 2.450
Availability: 5 business days

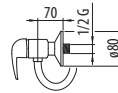

Comfort External Shower



18406 Chrome

With ceramic disk mixer
Non electronic operation
Package weight: Kg. 1:050
Availability: 5 business days

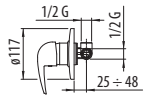

Transformers, batteries, flexible hoses, stop taps and accessories are all included in the price.

Certifications: **CE EMC ACS HACCP** Safety Transformer (230Vac/5Vdc)

Overview:

Compacto is a very versatile electronic tap, suitable to be installed in many environments and for many uses. One of its special features is the possibility of adjusting the sensors' range of action directly from the tap using the sensitivity regulator supplied for that purpose.

Version Available:

With built-in mixer.

Power Available:

3 AA 1.5 V alkaline batteries.
230Vac - 5Vdc safety transformer.

Pluses:

Photocell activation.
Water saving up to 80%.
Hygiene and wellbeing.
Easy to use.
Long battery life.
Sensor range adjustment directly on the tap.
100% Made in Italy.

Recommended for:

Catering



Public



Features:

- DMP photocell sensors, made of scratchproof and calcium resistant material
- Fully waterproof resined electronic circuit
- Chrome-plated brass body, constructed with specific vandal-proof criteria
- Stainless steel installation kit
- External adjustment of the sensor range (**FIG. 1**)
- DMP software programmed microchip for perfect function control
- Optimized functions for a long life of the alkaline batteries
- Autonomy of the batteries: 4-year battery life with 200 activations per day
- Low battery warning: a led in the sensors blinking twice every six seconds indicates that the batteries still have approx. 3 months autonomy
- Batteries easy to change and readily available (**FIG. 2**)
- Fully waterproof battery case
- Function for flood and consumption protection (**FIG. 3**)
- Optimized water consumption with limiter at 6 l/min. Optional: limiter at 3 l/min
- Solenoid valve with double anti-calcium filter
- Shut-off valves inside the recessed box, equipped with stainless steel, anti-calcium 0.2 mm mesh filters

Technical Specifications:

- AA 1.5 V alkaline batteries
- Electronic circuit: 4.5 V, manufactured in compliance with CEI EN 55014-1/-2 (EMC) requirements
- Solenoid valve: 3 V
- Safety transformer: 230Vac - 5Vdc, IMQ approved and manufactured in compliance with CEI EN 61558-1/-2-6 requirements
- IP65 electrical part protection grade
- Adjustable sensors' range of action: 8 - 35 cm
- Stop taps with non-return valves
- Water pressure: 0.4 - 10 bar
- Pipe fittings: 1/2 G

Package Contents:

- Electronic tap Compacto
- DMP fast connection flexible hoses
- DMP original stop taps
- Installation kit
- Instruction manual
- Battery case with 3 alkaline batteries
or
- DMP safety transformer

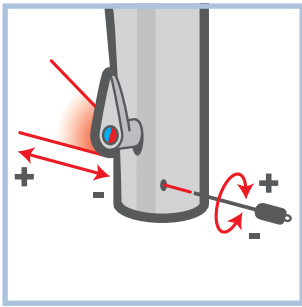

FIG. 1

Sensor range adjustment has never been this easy: just use the supplied mini-screwdriver on the rear of the tap.

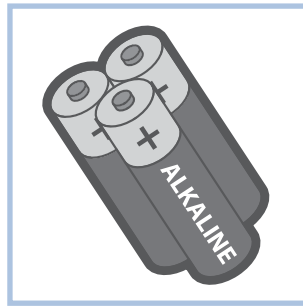

FIG. 2

Compacto uses batteries that are readily available: in hypermarkets as well as in corner shops. Easy to find, long-lasting.

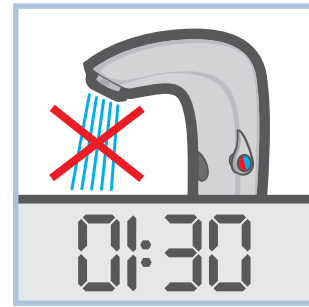

FIG. 3

The shut-off timer is a flood protection device that stops the water flow after one and a half minutes of continuous use. Maximum safety.

Compactomix BT



75906 Chrome
75903 White

With built-in mixer
Power: 3x1.5V AA alkaline batteries
Package weight: Kg. 2.600
Availability: 2 business days

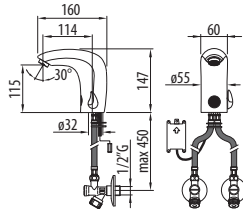

Compactomix



15906 Chrome
15903 White

With built-in mixer
Power: 5 Vdc transformer
Package weight: Kg. 2.700
Availability: 2 business days

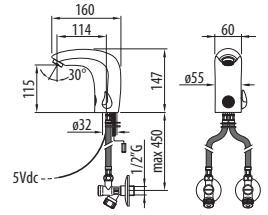

Transformers, batteries, flexible hoses, stop taps and accessories are all included in the price.

Certifications: **CE EMC ACS HACCP** **PCG** Safety Transformer **Ⓜ** (230Vac/5Vdc)

Overview:

The body shape comes from a single brass cast that is then chromium-plated to give Dia its characteristic tamper-proof monobloc structure. The essential line and lack of ruggedness make it a favourite for busy places where resistance and strength make the difference in terms of safety.

Versions Available:

With under washbasin mixer.
For cold or pre-mixed water.

Power Available:

3 AA 1.5 V alkaline batteries.
230Vac - 14Vac safety transformer.

Pluses:

Photocell activation.
Water saving up to 80%.
Hygiene and wellbeing.
Easy to use.
Long battery life.
Vandal-proof monobloc structure.
100% Made in Italy.

Recommended for:

Public



Features:

- DMP photocell sensors, made of scratchproof and calcium resistant material
- Fully waterproof resined electronic circuit
- Chrome-plated brass body or White, constructed with specific vandal-proof criteria (**FIG. 1**)
- Stainless steel installation kit
- DMP software programmed microchip for perfect function control
- Autonomy of the batteries: 3-year battery life with 200 activations per day
- Low battery warning: a led in the sensors blinking twice every six seconds indicates that the batteries still have approx. 3 months autonomy
- Batteries easy to change and readily available (**FIG. 2**)
- Fully waterproof battery case
- Function for flood and consumption protection: the DMP shut-off timer stops the water flow after 90 seconds of continuous use
- Optimized water consumption with limiter at 6 l/min. Optional: limiter at 3 l/min
- Optional: vandal-proof aerator
- Under washbasin mixer (**FIG. 3**)
- Solenoid valve with triple, stainless steel and anti-impurities filter
- Shut-off valves inside the recessed box, equipped with stainless steel, anti-impurities 0.2 mm mesh filters

Technical Specifications:

- AA 1.5 V alkaline batteries
- Electronic circuit: 4.5 V (battery powered models), 14 V (mains powered models)
- Solenoid valve: 3 V (battery powered models), 12 V (mains powered models)
- Safety transformer: 230Vac - 14Vac, IMQ approved and manufactured in compliance with CEI EN 61558-1/-2-6 requirements
- IP65 electrical part protection grade
- Adjustable sensors' range of action: 10 - 30 cm
- Stop taps with non-return valves
- Water pressure: 0.4 - 10 bar
- Pipe fittings: 1/2 G

Package Contents:

- Electronic tap Dia
- DMP fast connection flexible hoses
- DMP original stop taps
- Installation kit
- Instruction manual
- Battery case with 3 alkaline batteries
or
- DMP safety transformer

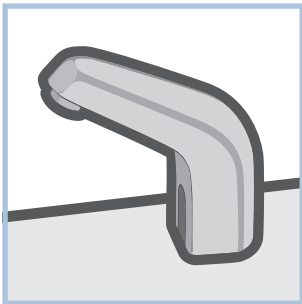

FIG. 1

The DIA structure is made of cast brass, creating a single unit that can guarantee maximum safety.

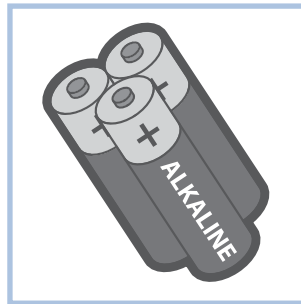

FIG. 2

DIA uses batteries that are readily available: in hypermarkets as well as in corner shops. Easy to find, long-lasting.

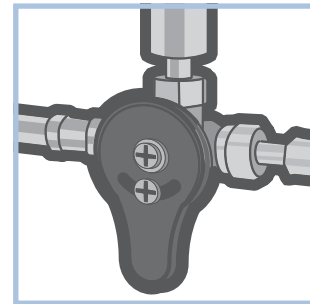

FIG. 3

The under washbasin mixer in all Diamix taps lets operators adjust the water temperature and block the knob with the appropriate screw.

Diamix 200 BT

61606 Chrome
61603 White

With under washbasin mixer*
Power: 3x1.5V AA alkaline batteries
Package weight: Kg. 2.900
Availability: 2 business days

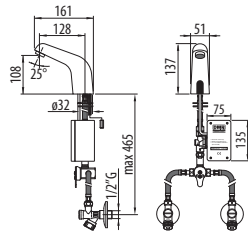

* The mixer handle can be blocked once the temperature is set.

Diamix 200

11506 Chrome
11503 White

With under washbasin mixer*
Power: 14 Vac transformer
Package weight: Kg. 2.750
Availability: 2 business days

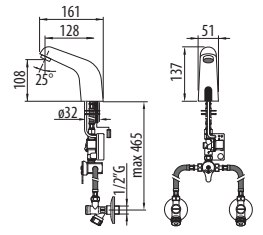

* The mixer handle can be blocked once the temperature is set.

Dia 1200 BT

61506 Chrome
61503 White

For cold or pre-mixed water
Power: 3x1.5V AA alkaline batteries
Package weight: Kg. 2.450
Availability: 2 business days

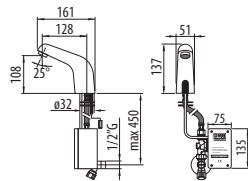

Dia 1200

11106 Chrome
11103 White

For cold or pre-mixed water
Power: 14 Vac transformer
Package weight: Kg. 2.300
Availability: 2 business days

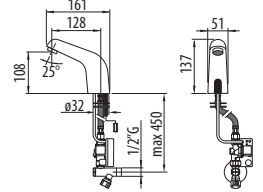

Transformers, batteries, flexible hoses, stop taps and accessories are all included in the price.

Certifications: **CE EMC ACS HACCP P_{CE}** Safety Transformer **Y** (230Vac/5Vdc)

On request, a vandal-proof aerator is available.

Overview:

With its modern and essential touch, Eco Plus combines design details with a high degree of advanced technology that becomes apparent through great easiness of use and maintenance. Its sensors' range of action can be adjusted right on the tap using the mini screwdriver supplied.

Versions Available:

With built-in mixer.

For cold or pre-mixed water.

With mixer in the tap body.

With under washbasin mixer

Power Available:

3 AA 1.5 V alkaline batteries.

230Vac - 5Vdc safety transformer.

Pluses:

Photocell activation.

Water saving up to 80%.

Hygiene and wellbeing.

Easy to use.

Long battery life.

Sensors' range adjustment directly on the tap.

100% Made in Italy.

Recommended for:

Catering



Hospitality



Institutions



Health



DMP recommends **Eco Plus** in combination with the electronic soap dispenser **Sanisoap Inox** (page 120) and with the electronic hand dryer **Turbo** (page 130). The three articles form the **Chrome Kit** (pages 12 and 13)

Features:

- DMP photocell sensors, made of scratchproof and calcium resistant material
- Fully waterproof resined electronic circuit
- Chrome-plated brass body, constructed with specific vandal-proof criteria
- Stainless steel installation kit
- External adjustment of the sensor range (**FIG. 1**)
- DMP software programmed microchip for perfect function control
- Optimized functions for a long life of the alkaline batteries
- Autonomy of the batteries: 4-year battery life with 200 activations per day
- Low battery warning: a led in the sensors blinking twice every six seconds indicates that the batteries still have approx. 3 months autonomy
- Batteries easy to change and readily available (**FIG. 2**)
- Fully waterproof battery case
- Function for flood and consumption protection (**FIG. 3**)
- Optimized water consumption with limiter at 6 l/min. Optional: limiter at 3 l/min
- Optional: vandal-proof aerator
- Solenoid valve with triple anti-calcium filter
- Shut-off valves inside the recessed box, equipped with stainless steel, anti-calcium 0.2 mm mesh filters

Technical Specifications:

- AA 1.5 V alkaline batteries
- Electronic circuit: 4.5 V, manufactured in compliance with CEI EN 55014-1/-2 (EMC) requirements
- Solenoid valve: 3 V
- Safety transformer: 230Vac - 5Vdc, IMQ approved and manufactured in compliance with CEI EN 61558-1/-2-6 requirements
- IP65 electrical part protection grade
- Adjustable sensors' range of action: 8 - 35 cm
- Stop taps with non-return valves
- Water pressure: 0.4 - 10 bar
- Pipe fittings: 1/2 G

Package Contents:

- Electronic tap Eco Plus
- DMP fast connection flexible hoses
- DMP original stop taps
- Installation kit
- Instruction manual
- Battery case with 3 alkaline batteries
or
- DMP safety transformer

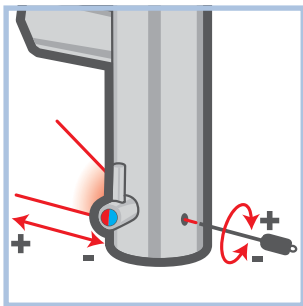

FIG. 1

Sensor sensitivity adjustment has never been this easy: just use the supplied mini-screwdriver on the rear of the faucet.

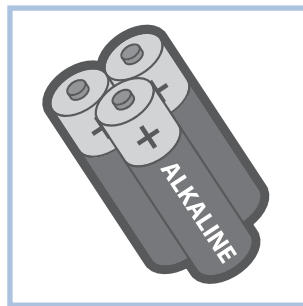

FIG. 2

Eco Plus uses batteries that are readily available: in hypermarkets as well as in corner shops. Easy to find, long-lasting.



FIG. 3

The shut-off timer is a flood protection device that stops the water flow after one and a half minutes of continuous use. Maximum home safety.

Ecomix Plus 113 BT



87806 Chrome

With built-in mixer
 Power: 3x1.5V AA alkaline batteries
 Package weight: Kg. 3.100
 Availability: 2 business days

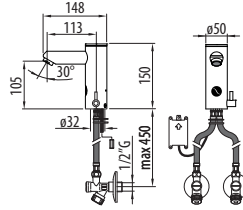

Ecomix Plus 113



27806 Chrome

With built-in mixer
 Power: 5 Vdc transformer
 Package weight: Kg. 3.200
 Availability: 2 business days

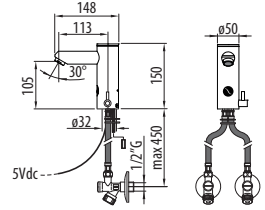

Eco Plus 113 BT



88106 Chrome

For cold or pre-mixed water
 Power: 3x1.5V AA alkaline batteries
 Package weight: Kg. 2.900
 Availability: 2 business days

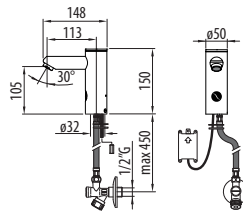

Eco Plus 113



28106 Chrome

For cold or pre-mixed water
 Power: 5 Vdc transformer
 Package weight: Kg. 3.000
 Availability: 2 business days

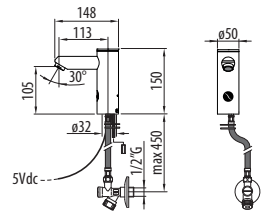

Eco Plus MS BT



88506 Chrome

With under washbasin mixer*
 Power: 3x1.5V AA alkaline batteries
 Package weight: Kg. 3.200
 Availability: 5 business days

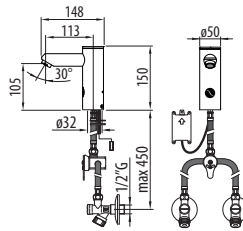

Eco Plus MS



28506 Chrome

With under washbasin mixer*
 Power: 5 Vdc transformer
 Package weight: Kg. 3.300
 Availability: 5 business days

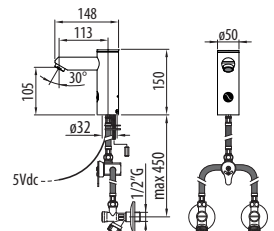

* The mixer handle can be blocked once the temperature is set.

* The mixer handle can be blocked once the temperature is set.

Eco Plus TL BT



87817 Chrome

With internal mixer*
 Power: 3x1.5V AA alkaline batteries
 Package weight: Kg. 3.000
 Availability: 5 business days

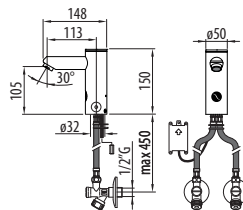

Eco Plus TL



27817 Chrome

With internal mixer*
 Power: 5 Vdc transformer
 Package weight: Kg. 3.100
 Availability: 5 business days

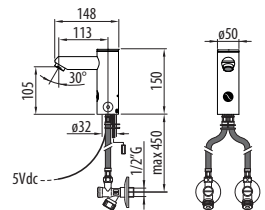

* Temperature adjustment on tap, with vandal-proof safety stopper.

* Temperature adjustment on tap, with vandal-proof safety stopper.

Transformers, batteries, flexible hoses, stop taps and accessories are all included in the price.

Certifications: **CE EMC ACS HACCP** **PG** Safety Transformer **Y** (230Vac/5Vdc)

On request, a vandal-proof aerator is available.

Overview:

Sette is an extremely compact electronic tap, designed and manufactured with innovative criteria aimed at optimizing energy consumption and protecting the environment. Very easy to install, Sette is the best solution for small spaces and for small sized washbasins.

Versions Available:

With built-in mixer.

For cold or pre-mixed water.

With mixer in the tap body.

With under washbasin mixer

Power Available:

3 AA 1.5 V alkaline batteries.

230Vac - 5Vdc safety transformer.

Pluses:

Photocell activation.

Water saving up to 80%.

Hygiene and wellbeing.

Easy to use.

Long battery life.

Compact and resistant.

Ideal for small washbasins.

100% Made in Italy.

Recommended for:

Catering



Public



Institutions



Health



Industry



Features:

- DMP photocell sensors, made of scratchproof and calcium resistant material (**FIG. 1**)
- Fully waterproof resined electronic circuit
- Chrome-plated brass body constructed with specific vandal-proof criteria (**FIG. 2**)
- Stainless steel installation kit
- DMP software programmed microchip for perfect function control
- Optimized functions for a long life of the alkaline batteries
- Autonomy of the batteries: 4-year battery life with 200 activations per day
- Low battery warning: a led in the sensors blinking twice every six seconds indicates that the batteries still have approx. 3 months autonomy
- Batteries easy to change and readily available (**FIG. 3**)
- Fully waterproof battery case
- Function for flood and consumption protection: the DMP shut-off timer stops the water flow after 90 seconds of continuous use
- Optimized water consumption with limiter at 6 l/min. Optional: limiter at 3 l/min
- Optional: vandal-proof aerator
- Solenoid valve with triple, stainless steel and anti-impurities filter

- Shut-off valves inside the recessed box, equipped with stainless steel, anti-impurities 0.2 mm mesh filters

Technical Specifications:

- AA 1.5 V alkaline batteries
- Electronic circuit: 4.5 V, manufactured in compliance with CEI EN 55014-1/-2 (EMC) requirements
- Solenoid valve: 3 V
- Safety transformer: 230Vac - 5Vdc, IMQ approved and manufactured in compliance with CEI EN 61558-1/-2-6 requirements
- IP65 electrical part protection grade
- Adjustable sensors' range of action: 8 - 35 cm
- Stop taps with non-return valves
- Water pressure: 0.4 - 10 bar
- Pipe fittings: 1/2 G

Package Contents:

- Electronic tap Sette
- DMP fast connection flexible hoses
- DMP original stop taps
- Installation kit
- Instruction manual
- Battery case with 3 alkaline batteries
or
- DMP safety transformer

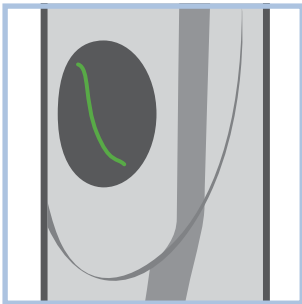

FIG. 1

Sette comes with newly designed, ultra-sensitive and super-accurate sensors and a green comma symbolizing that DMP products are eco-friendly.

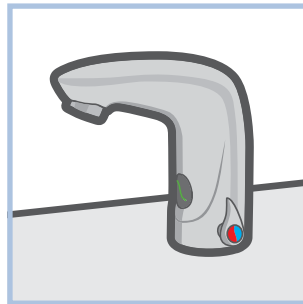

FIG. 2

Inspired by last generation engineering criteria, Sette is extremely compact, making it suitable for washbasins of any size.

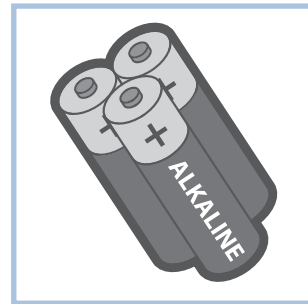

FIG. 3

Sette uses batteries that are readily available: in supermarkets as well as in corner shops. Easy to find, long-lasting.

Settemix BT



83706 Chrome

With built-in mixer
 Power: 3x1.5V AA alkaline batteries
 Package weight: Kg. 2.250
 Availability: 2 business days

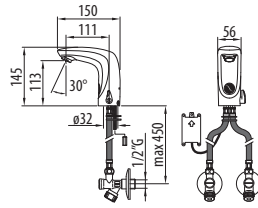

Settemix



23706 Chrome

With built-in mixer
 Power: 5 Vdc transformer
 Package weight: Kg. 2.350
 Availability: 2 business days

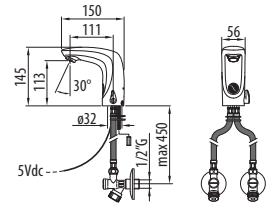

Sette BT



83806 Chrome

For cold or pre-mixed water
 Power: 3x1.5V AA alkaline batteries
 Package weight: Kg. 2.000
 Availability: 2 business days

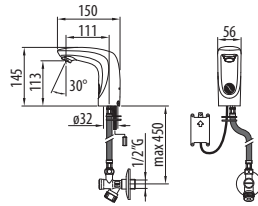

Sette



23806 Chrome

For cold or pre-mixed water
 Power: 5 Vdc transformer
 Package weight: Kg. 2.100
 Availability: 2 business days

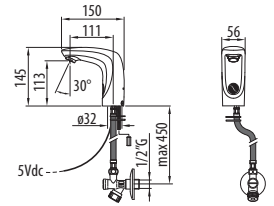

Sette MS BT



83906 Chrome

With under washbasin mixer *
 Power: 3x1.5V AA alkaline batteries
 Package weight: Kg. 2.450
 Availability: 5 business days

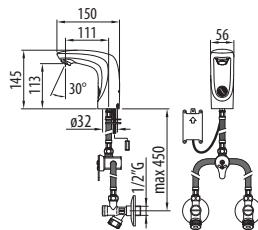

Sette MS



23906 Chrome

With under washbasin mixer *
 Power: 5 Vdc transformer
 Package weight: Kg. 2.550
 Availability: 5 business days

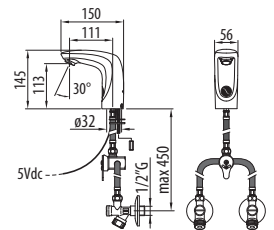

* The mixer handle can be blocked once the temperature is set.

* The mixer handle can be blocked once the temperature is set.

Sette TL BT



83717 Chrome

With internal mixer *
 Power: 3x1.5V AA alkaline batteries
 Package weight: Kg. 2.200
 Availability: 5 business days

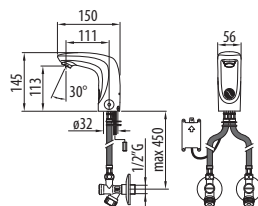

Sette TL



23717 Chrome

With internal mixer *
 Power: 5 Vdc transformer
 Package weight: Kg. 2.300
 Availability: 5 business days

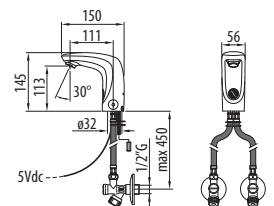

* Temperature adjustment on tap, with vandal-proof safety stopper.

* Temperature adjustment on tap, with vandal-proof safety stopper.

Transformers, batteries, flexible hoses, stop taps and accessories are all included in the price.

Certifications: **CE EMC ACS HACCP** **PG** Safety Transformer **M** (230Vac/5Vdc)

On request, a vandal-proof aerator is available.

Overview:

Tube's essentiality translates in a sense of weightlessness, airiness and sophistication that adds value to the context, becoming an integral part of the furniture. The series includes the whole kit of bathroom taps, both electronic and manual, according to the model. The washbasin and bidet electronic models are fitted with a constant flow or stop button.

Versions Available:

Tube washbasin (electronic).

Tube bidet (electronic or manual)

Tube tub (manual)

Tube shower (manual)

Power Available:

3 AA 1.5 V alkaline batteries.

230Vac - 5Vdc safety transformer.

Pluses:

Kit complete of taps for the bathroom.

Photocell activation. *

Water saving up to 80%. *

Hygiene and wellbeing. *

Easy to use. *

Long battery life. *

Button for continuous flow or stop flow mode. *

100% Made in Italy. *

Recommended for:



Residential



Hospitality



Catering

** Pluses refer to electronic models for washbasins and bidets*



Features:

- DMP photocell sensors, made of scratchproof and calcium resistant material
- Fully waterproof resined electronic circuit
- Chrome-plated brass body
- Stainless steel installation kit
- DMP software programmed microchip for perfect function control
- Optimized functions for a long life of the alkaline batteries
- Autonomy of the batteries: 4-year battery life with 200 activations per day
- Low battery warning: a led in the sensors blinking twice every six seconds indicates that the batteries still have approx. 3 months autonomy
- Batteries easy to change and readily available
- Fully waterproof battery case
- Continuous water flow mode (**FIG. 1**)
- Temporary tap stop function (**FIG. 2**)
- Function for flood and consumption protection (**FIG. 3**)
- Optimized water consumption with limiter at 6 l/min. Optional: limiter at 3 l/min
- Solenoid valve with triple anti-calcium filter
- Shut-off valves inside the recessed box, equipped with stainless steel, anti-calcium 0.2 mm mesh filters

Technical Specifications:

- AA 1.5 V alkaline batteries
- Electronic circuit: 4.5 V, manufactured in compliance with CEI EN 55014-1/-2 (EMC) requirements
- Solenoid valve: 3 V
- Safety transformer: 230Vac - 5Vdc, IMQ approved and manufactured in compliance with CEI EN 61558-1/-2-6 requirements
- IP65 electrical part protection grade
- Adjustable sensor range of action: 8 - 35 cm
- Stop taps with non-return valves
- Water pressure: 0.4 - 10 bar
- Pipe fittings: 1/2 G

Package Contents:

- Electronic tap Tube Plus
- DMP fast connection flexible hoses
- DMP original stop taps
- Installation kit
- Instruction manual
- Battery case with 3 alkaline batteries
or
- DMP safety transformer

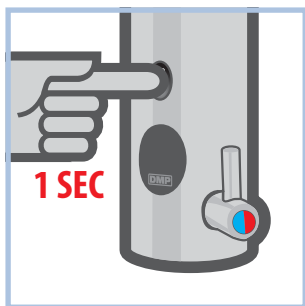

FIG. 1

Press the Tube Plus multi-function button for 1 second to activate continuous flow mode. Press again for 1 second to revert to electronic automatic mode.

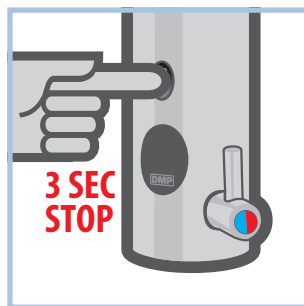

FIG. 2

Press and hold the button down for 3 seconds to activate stop mode, practical for washbasin cleaning. Press and hold down again for 3 seconds to restart.

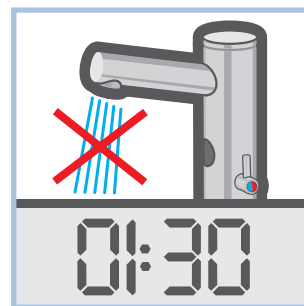

FIG. 3

The shut-off timer is a flood protection device that stops the water flow after one and a half minutes of continuous use. Maximum home safety.

Tube Plus Washbasin BT



89406.PL Chrome
With multifunction button

89406 Chrome
Without multifunction button

With built-in mixer
Power: 3x1.5V AA alkaline batteries
Package weight: Kg. 3.100
Availability: 5 business days

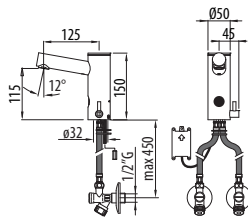

Tube Plus L Washbasin



29406.PL Chrome
With multifunction button

29406 Chrome
Without multifunction button

With built-in mixer
Power: 5 Vdc transformer
Package weight: Kg. 3.200
Availability: 5 business days

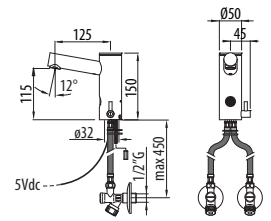

Tube Bidet Electronic BT



89906 Chrome

With built-in mixer
Power: 3x1.5V AA alkaline batteries
Package weight: Kg. 2.700
Availability: 5 business days

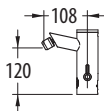

Tube Bidet Electronic



29906 Chrome

With built-in mixer
Power: 5 Vdc transformer
Package weight: Kg. 2.800
Availability: 5 business days

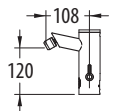

Tube Bidet



21506 Chrome

With ceramic disk mixer
Non electronic operation
Package weight: Kg. 2.000
Availability: 5 business days

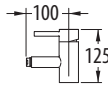

Tube Tub



21606 Chrome

With ceramic disk mixer
Non electronic operation
Package weight: Kg. 3.200
Availability: 5 business days

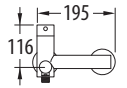

Tube External Shower



21806 Chrome

With ceramic disk mixer
Non electronic operation
Package weight: Kg. 2.600
Availability: 5 business days

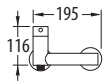

Tube External Shower



21706 Chrome

With ceramic disk mixer
Non electronic operation
Package weight: Kg. 1.150
Availability: 5 business days

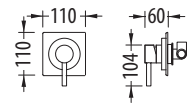

Tube Plus Washbasin



Tube bidet



Tube tub



Tube External Shower

Tube Plus Washbasin is available in other versions as well. For details, refer to DMP's price list.

Transformers, batteries, flexible hoses and stop taps are all included in the price.

Certifications: **CE EMC ACS HACCP** Safety Transformer (230Vac/5Vdc)

Up-down control rod and drain/pop-up stopper are supplied on request.

Overview:

Under the shape of classical lines, Arco Plus hides its true nature, modern and technological, designed inside a chrome-plated cylinder containing the solenoid valve and the ultra-sensitive photocells. In the version with an umbrella handle shaped spout Arco Plus is the ideal solution for the medical/hospital sector.

Versions Available:

With built-in mixer.

For cold or pre-mixed water.

With mixer in the tap body.

With under washbasin mixer

Power Available:

3 AA 1.5 V alkaline batteries.

230Vac - 5Vdc safety transformer.

Pluses:

Photocell activation.

Water saving up to 80%.

Hygiene and wellbeing.

Easy to use.

Long battery life.

Button for continuous flow or stop flow mode.

Available in three spout lengths.

100% Made in Italy.

Recommended for:

Health



Hospitality



Catering



Features:

- DMP photocell sensors, made of scratchproof and calcium resistant material
- Fully waterproof resined electronic circuit
- Chrome-plated brass body, constructed with specific vandal-proof criteria
- Spout lengths: 135 mm, 155 mm, 195 mm (**FIG. 1**)
- Stainless steel installation kit
- External adjustment of the sensor range (**FIG. 2**)
- DMP software programmed microchip for perfect function control
- Optimized functions for a long life of the alkaline batteries
- Autonomy of the batteries: 4-year battery life with 200 activations per day
- Low battery warning: a led in the sensors blinking twice every six seconds indicates that the batteries still have approx. 3 months autonomy
- Batteries easy to change and readily available (**FIG. 3**)
- Fully waterproof battery case
- Function for flood and consumption protection: the DMP shut-off timer stops the water flow after 90 seconds of continuous use
- Optimized water consumption with limiter at 6 l/min. Optional: limiter at 3 l/min
- Solenoid valve with double, stainless steel and anti-impurities filter

- Shut-off valves inside the recessed box, equipped with stainless steel, anti-impurities 0.2 mm mesh filters

Technical Specifications:

- AA 1.5 V alkaline batteries
- Electronic circuit: 4.5 V, manufactured in compliance with CEI EN 55014-1/-2 (EMC) requirements
- Solenoid valve: 3 V
- Safety transformer: 230Vac - 5Vdc, IMQ approved and manufactured in compliance with CEI EN 61558-1/-2-6 requirements
- IP65 electrical part protection grade
- Adjustable sensors' range of action: 8 - 35 cm
- Stop taps with non-return valves
- Water pressure: 0.4 - 10 bar
- Pipe fittings: 1/2 G

Package Contents:

- Electronic tap Arco Plus
- DMP fast connection flexible hoses
- DMP original stop taps
- Installation kit
- Instruction manual
- Battery case with 3 alkaline batteries
or
- DMP safety transformer



FIG. 1

In the versions with 155 and 195 mm spouts, the Arco Plus models are ideal for physicians and surgeons who require maximum hand and arm hygiene.

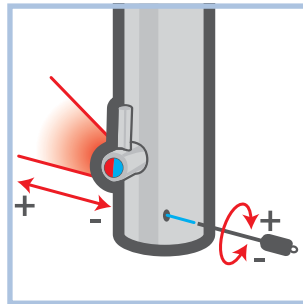

FIG. 2

Sensor sensitivity adjustment has never been this easy: just use the supplied mini-screwdriver on the rear of the tap.

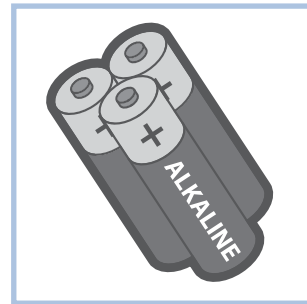

FIG. 3

Arco Plus uses batteries that are readily available: in supermarkets as well as in corner shops. Easy to find, long-lasting.

Arcomix plus BT



- 85306.PL Arcomix plus 135 BT** Spout 135 mm
With multifunction button
- 85306 Arcomix plus 135 BT** Spout 135 mm
Without multifunction button
- 85356.PL Arcomix plus 155 BT** Spout 155 mm
With multifunction button
- 85356 Arcomix plus 155 BT** Spout 155 mm
Without multifunction button
- 85396.PL Arcomix plus 195 BT** Spout 195 mm
With multifunction button
- 85396 Arcomix plus 195 BT** Spout 195 mm
Without multifunction button

Colour: chrome
With built-in mixer
Power: 3x1.5V AA alkaline batteries
Package weight: Kg. 2.400 ÷ 2.500
Availability: 2/5 business days
Fixed spout

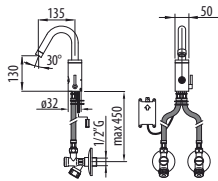

Arco plus BT



- 85206.PL Arco plus 135 BT** Spout 135 mm
With multifunction button
- 85206 Arco plus 135 BT** Spout 135 mm
Without multifunction button
- 85256.PL Arco plus 155 BT** Spout 155 mm
With multifunction button
- 85256 Arco plus 155 BT** Spout 155 mm
Without multifunction button
- 85296.PL Arco plus 195 BT** Spout 195 mm
With multifunction button
- 85296 Arco plus 195 BT** Spout 195 mm
Without multifunction button

Colour: chrome
For cold or pre-mixed water
Power: 3x1.5V AA alkaline batteries
Package weight: Kg. 2.300 ÷ 2.400
Availability: 2/5 business days
Fixed spout

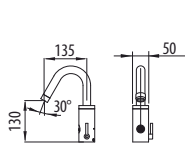
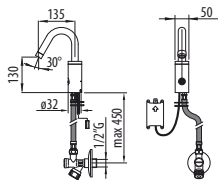

ARCO PLUS 135

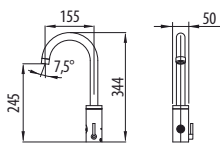

ARCO PLUS 155

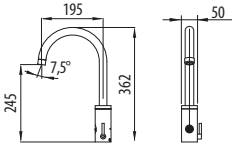

ARCO PLUS 195

Arcomix plus



- 25306.PL Arcomix plus 135** Spout 135 mm
With multifunction button
- 25306 Arcomix plus 135** Spout 135 mm
Without multifunction button
- 25356.PL Arcomix plus 155** Spout 155 mm
With multifunction button
- 25356 Arcomix plus 155** Spout 155 mm
Without multifunction button
- 25396.PL Arcomix plus 195** Spout 195 mm
With multifunction button
- 25396 Arcomix plus 195** Spout 195 mm
Without multifunction button

Colour: chrome
With built-in mixer
Power: 5 Vdc transformer
Package weight: Kg. 2.500 ÷ 2.600
Availability: 2/5 business days
Fixed spout

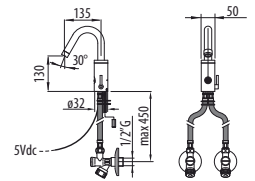

Arco plus



- 25206.PL Arco plus 135** Spout 135 mm
With multifunction button
- 25206 Arco plus 135** Spout 135 mm
Without multifunction button
- 25256.PL Arco plus 155** Spout 155 mm
With multifunction button
- 25256 Arco plus 155** Spout 155 mm
Without multifunction button
- 25296.PL Arco plus 195** Spout 195 mm
With multifunction button
- 25296 Arco plus 195** Spout 195 mm
Without multifunction button

Colour: chrome
For cold or pre-mixed water
Power: 5 Vdc transformer
Package weight: Kg. 2.400 ÷ 2.500
Availability: 2/5 business days
Fixed spout

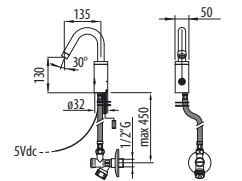

Transformers, batteries, flexible hoses and stop taps are all included in the price.

Certifications: **CE EMC ACS HACCP** **PG** Safety Transformer **TM** (230Vac/5Vdc)

Up-down control rod and drain/pop-up stopper are supplied on request.

Overview:

Billo is a fixed spout electronic tap suitable for every type of public use: public washrooms, hotels, stores. Its appearance is discreet, modern while well-known and recognisable, with a curved and elongated spout that accompanies the well-regulated water flow.

Versions Available:

With under washbasin mixer.
For cold or pre-mixed water.

Power Available:

3 AA 1.5 V alkaline batteries.
230Vac - 14Vac safety transformer.

Pluses:

Photocell activation.
Water saving up to 80%.
Hygiene and wellbeing.
Easy to use.
Long battery life.
Available in three lengths of spout.
100% Made in Italy.

Recommended for:

Public



Catering



Features:

- DMP photocell sensors, made of scratchproof and calcium resistant material (**FIG. 1**)
- Fully waterproof resined electronic circuit
- Chrome-plated brass body constructed with specific vandal-proof criteria
- Spout lengths: 115 mm, 160 mm, 185 mm (**FIG. 2**)
- Stainless steel installation kit
- DMP software programmed microchip for perfect function control
- Optimized functions for a long life of the alkaline batteries
- Autonomy of the batteries: 4-year battery life with 200 activations per day
- Low battery warning: a led in the sensors blinking twice every six seconds indicates that the batteries still have approx. 3 months autonomy
- Batteries easy to change and readily available (**FIG. 3**)
- Fully waterproof battery case
- Function for flood and consumption protection: the DMP shut-off timer stops the water flow after 90 seconds of continuous use
- Optimized water consumption with limiter 6 l/min
- Solenoid valve with triple, stainless steel and anti-impurities filter
- Shut-off valves inside the recessed box, equipped with stainless steel, anti-impurities 0.2 mm mesh filters

Technical Specifications:

- AA 1.5 V alkaline batteries
- Electronic circuit: 4.5 V (battery powered models); 12 V (mains powered models)
- Solenoid valve: 3 V (battery powered models); 12 V (mains powered models)
- Safety transformer: 230Vac - 14Vac, IMQ approved and manufactured in compliance with CEI EN 61558-1/-2-6 requirements
- IP65 electrical part protection grade
- Adjustable sensors' range of action: 10 - 30 cm
- Stop taps with non-return valves
- Water pressure: 0.4 - 10 bar
- Pipe fittings: 1/2 G

Package Contents:

- Electronic tap Billo
- DMP fast connection flexible hoses
- DMP original stop taps
- Installation kit
- Instruction manual
- Battery case with 3 alkaline batteries
or
- DMP safety transformer



FIG. 1

BILLO is equipped with the proven DMP INFRARED SYSTEM: smooth, easy to clean sensors on the outside, all the advanced DMP Electronics technology on the inside.



FIG. 2

In the versions with 160 and 185 mm spouts the Billo models are ideal for physicians and surgeons who require maximum hand and arm hygiene.

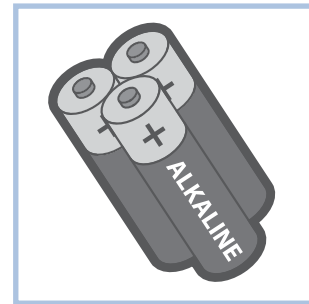

FIG. 3

BILLO uses batteries that are readily available: in hypermarkets as well as in corner shops. Easy to find, long-lasting.

Billotap BT

- 76106 Billotap 108 BT Spout 115 mm**
- 76156 Billotap 115 BT Spout 160 mm**
- 76196 Billotap 119 BT Spout 185 mm**



Colour: chrome
 For cold or pre-mixed water
 Power: 3x1.5V AA alkaline batteries
 Package weight: Kg. 1.950 ÷ 2.300
 Availability: 3/5 business days
 Fixed spout

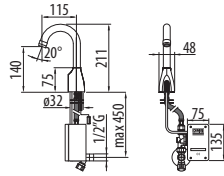

Billotap

- 16106 Billotap 108 Spout 115 mm**
- 16156 Billotap 115 Spout 160 mm**
- 16196 Billotap 119 Spout 185 mm**



Colour: chrome
 For cold or pre-mixed water
 Power: transformer 14Vac
 Package weight: Kg. 1.900 ÷ 2.250
 Availability: 3/5 business days
 Fixed spout

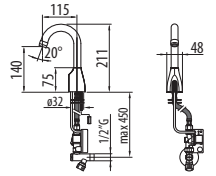

- 76386 Billotap 308 BT Spout 115 mm**
- 76356 Billotap 315 BT Spout 160 mm**
- 76396 Billotap 319 BT Spout 185 mm**



Colour: chrome
 With under washbasin mixer*
 Power: 3x1.5V AA alkaline batteries
 Package weight: Kg. 2.450 ÷ 2.600
 Availability: 2/5 business days
 Fixed spout

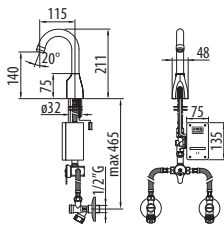

- 16386 Billotap 308 Spout 115 mm**
- 16356 Billotap 315 Spout 160 mm**
- 16396 Billotap 319 Spout 185 mm**



Colour: chrome
 With under washbasin mixer*
 Power: transformer 14Vac
 Package weight: Kg. 2.400 ÷ 2.550
 Availability: 2/5 business days
 Fixed spout

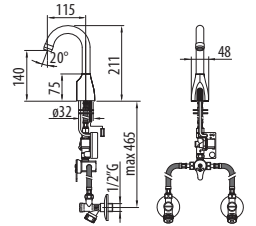

* The mixer handle can be blocked once the temperature is set.

* The mixer handle can be blocked once the temperature is set.

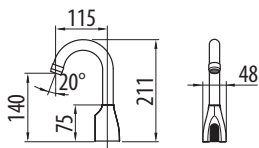

BILLOTAP 108/308

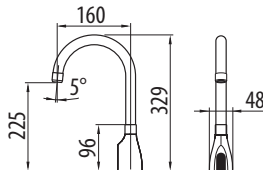

BILLOTAP 115/315

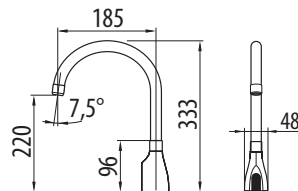

BILLOTAP 119/319

Transformers, batteries, flexible hoses, stop taps and accessories are all included in the price.

Certifications: **CE EMC ACS HACCP** **PG** Safety Transformer **TM** (230Vac/14Vac)

Overview:

The constant technological evolution of our research department has allowed us to develop an increasing number of new products and to add functions to the existing models. That's how Billo Plus came into being: an electronic tap with a totally updated line and concept in comparison with the classical Billo. New models and solutions are added and the Mix version boasts a mixer for water temperature control.

Versions Available:

With built-in mixer.

For cold or pre-mixed water.

With mixer in the tap body.

With under washbasin mixer

Power Available:

3 AA 1.5 V alkaline batteries.

230Vac - 5Vdc safety transformer.

Pluses:

Photocell activation.

Water saving up to 80%.

Hygiene and wellbeing.

Easy to use.

Long battery life.

100% Made in Italy.

Recommended for:

Public



Catering



Hospitality



Features:

- DMP photocell sensors, made of scratchproof and calcium resistant material
- Fully waterproof resined electronic circuit
- Chrome-plated brass body constructed with specific vandal-proof criteria
- Stainless steel installation kit
- External adjustment of the sensor range (**FIG. 1**)
- DMP software programmed microchip for perfect function control
- Optimized functions for a long life of the alkaline batteries
- Autonomy of the batteries: 4-year battery life with 200 activations per day
- Low battery warning: a led in the sensors blinking twice every six seconds indicates that the batteries still have approx. 3 months autonomy
- Batteries easy to change and readily available (**FIG. 2**)
- Fully waterproof battery case
- Function for flood and consumption protection: the DMP shut-off timer stops the water flow after 90 seconds of continuous use
- Optimized water consumption with limiter at 6 l/min
- Solenoid valve with triple, stainless steel and anti-impurities filter
- Under washbasin mixer with knob blocker (**FIG. 3**)

- Shut-off valves inside the recessed box, equipped with stainless steel, anti-impurities 0.2 mm mesh filters

Technical Specifications:

- AA 1.5 V alkaline batteries
- Electronic circuit: 4.5 V, manufactured in compliance with CEI EN 55014-1/-2 (EMC) requirements
- Solenoid valve: 3 V
- Safety transformer: 230Vac - 14Vac, IMQ approved and manufactured in compliance with CEI EN 61558-1/-2-6 requirements
- IP65 electrical part protection grade
- Adjustable sensors' range of action: 10 - 30 cm
- Stop taps with non-return valves
- Water pressure: 0.4 - 10 bar
- Pipe fittings: 1/2 G

Package Contents:

- Electronic tap Billo Plus
- DMP fast connection flexible hoses
- DMP original stop taps
- Installation kit
- Instruction manual
- Battery case with 3 alkaline batteries
or
- DMP safety transformer

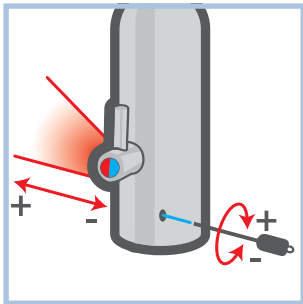

FIG. 1

Sensor sensitivity adjustment has never been this easy: just use the supplied mini-screwdriver on the rear of the tap.

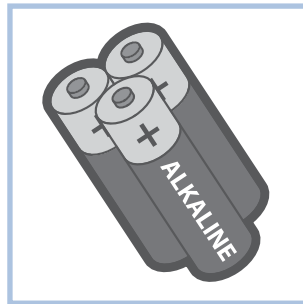

FIG. 2

Billo Plus uses batteries that are readily available: in hypermarkets as well as in corner shops. Easy to find, long-lasting.

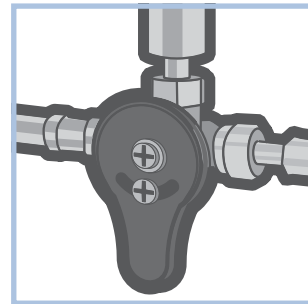

FIG. 3

An under washbasin mixer is included in the Billo Plus MS: operators can adjust the water temperature and block the knob with the appropriate screw.

BilloMix Plus 115 BT



87106 Chrome

With built-in mixer
 Power: 3x1.5V AA alkaline batteries
 Package weight: Kg. 2.100
 Availability: 2 business days
 Fixed spout

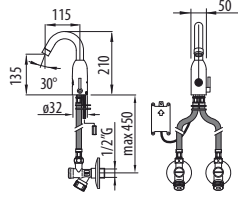

BilloMix Plus 115



27106 Chrome

With built-in mixer
 Power: 5 Vdc transformer
 Package weight: Kg. 2.200
 Availability: 2 business days
 Fixed spout

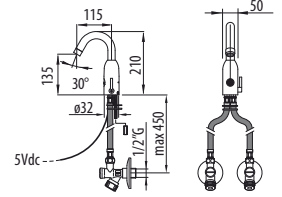

Billo Plus 115 BT



86906 Chrome

For cold or pre-mixed water
 Power: 3x1.5V AA alkaline batteries
 Package weight: Kg. 1.900
 Availability: 2 business days
 Fixed spout

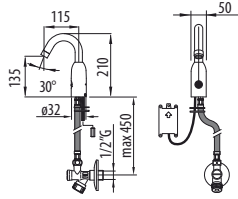

Billo Plus 115



26906 Chrome

For cold or pre-mixed water
 Power: 5 Vdc transformer
 Package weight: Kg. 2.000
 Availability: 2 business days
 Fixed spout

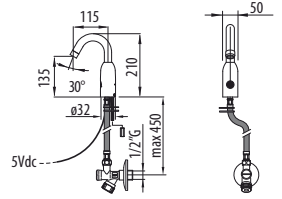

Billo Plus 115 MS BT



87206 Chrome

With under washbasin mixer*
 Power: 3x1.5V AA alkaline batteries
 Package weight: Kg. 2.300
 Availability: 5 business days
 Fixed spout

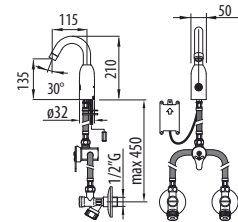

Billo Plus 115 MS



27206 Chrome

With under washbasin mixer*
 Power: 5 Vdc transformer
 Package weight: Kg. 2.400
 Availability: 5 business days
 Fixed spout

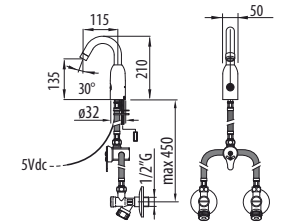

* The mixer handle can be blocked once the temperature is set.

* The mixer handle can be blocked once the temperature is set.

Billo Plus 115 TL BT



87117 Chrome

With internal mixer*
 Power: 3x1.5V AA alkaline batteries
 Package weight: Kg. 2.000
 Availability: 5 business days
 Fixed spout

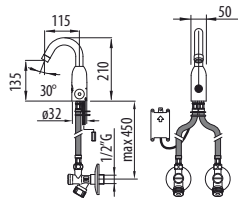

Billo Plus 115 TL



27117 Chrome

With internal mixer*
 Power: 5 Vdc transformer
 Package weight: Kg. 2.100
 Availability: 5 business days
 Fixed spout

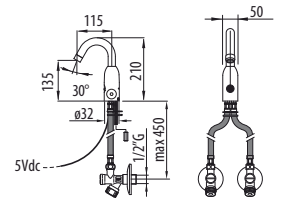

* Temperature adjustment on tap, with vandal-proof safety stopper.

* Temperature adjustment on tap, with vandal-proof safety stopper.

Transformers, batteries, flexible hoses, stop taps and accessories are all included in the price.

Certifications: **CE EMC ACS HACCP** **PG** Safety Transformer **TM** (230Vac/5Vdc)

Arco Plus RZ 3

Extension 20 mm
for recessed washbasin

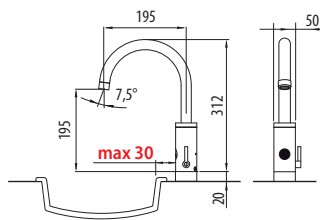

Arco Plus RZ 2

Extension 85 mm
for washbasin H 80 mm max

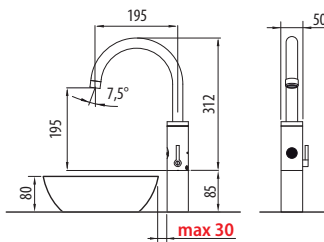

Arco Plus RZ 1

Extension 170 mm
for washbasin H 155 mm max

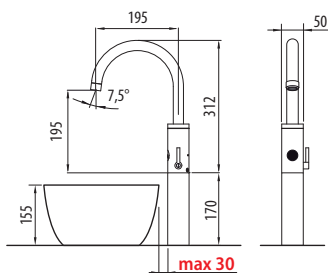

Arco Plus RZ N

Extension 200 mm
for washbasin H 185 mm max

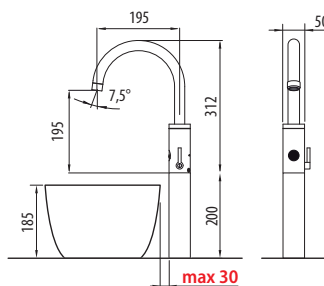

Arco Plus RZ 9

Extension 860 mm
for floor washbasin

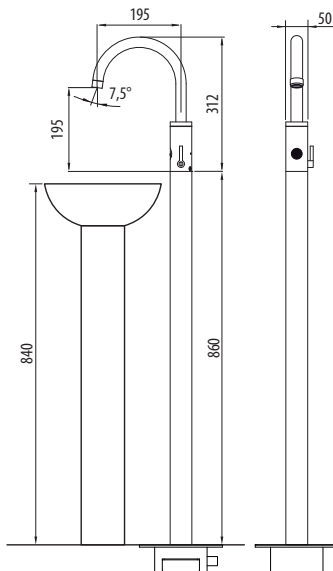

The **Arco Plus RZ** line includes **32 models** to fulfill and satisfy all customers' and dealers' requirements. Models are available with the following features:

- Hot/cold water with built-in mixer
- Cold or pre-mixed water
- Power with 3x1.5V AA alkaline batteries
- Power with 230Vac/5Vdc transformer
- With multifunction button
- Without multifunction button

For further details, please refer to DMP Electronics price list

Transformers, batteries, flexible hoses and stop taps are all included in the price.

Certifications: **CE EMC ACS HACCP** 

Safety Transformer  (230Vac/5Vdc)

Up-down control rod and drain/pop-up stopper are supplied on request.



Recommended for:



Hospitality



Catering



Residential

Tube Plus RZ 3

Extension 20 mm
for recessed washbasin

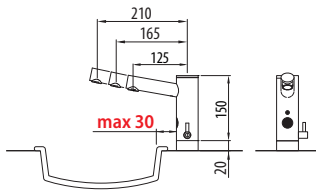

Tube Plus RZ 2

Extension 85 mm
for washbasin H 80 mm max

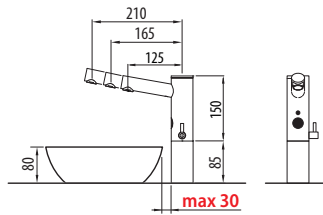

Tube Plus RZ 5

Extension 125 mm
for washbasin H 110 mm max

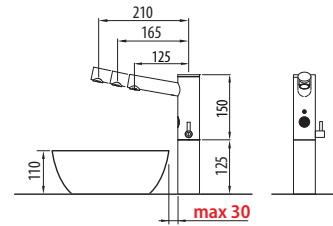

Tube Plus RZ 1

Extension 170 mm
for washbasin H 155 mm max

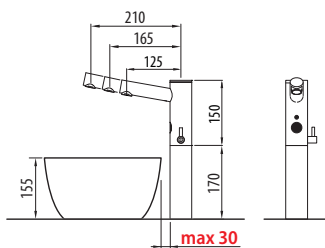

Tube Plus RZ N

Extension 200 mm
for washbasin H 185 mm max

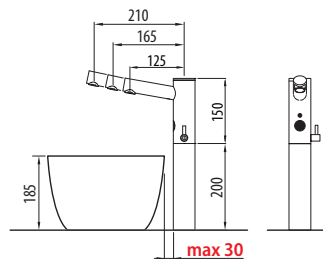

Tube Plus RZ 6

Extension 230 mm
for washbasin H 215 mm max

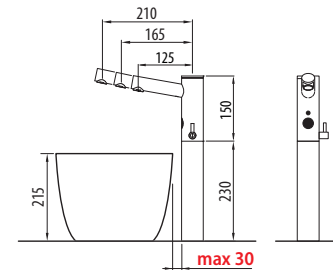

Tube Plus RZ 9

Extension 860 mm
for floor washbasin

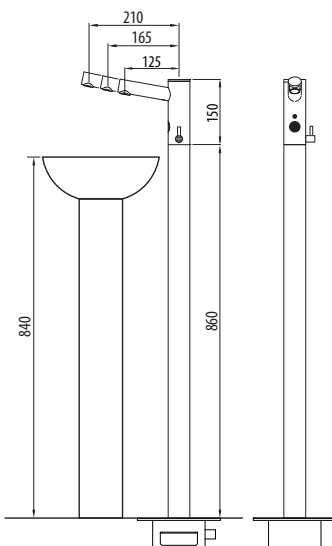

The **Tube Plus RZ** line includes **168 models** to fulfill and satisfy all customers' and dealers' requirements. Models are available with the following features:

- Hot/cold water with built-in mixer
- Cold or pre-mixed water
- Power with 3x1.5V AA alkaline batteries
- Power with 230Vac/5Vdc transformer
- With multifunction button
- Without multifunction button
- Spout lengths: 125 mm - 165 mm - 210 mm

For further details, please refer to DMP Electronics price list

Transformers, batteries, flexible hoses and stop taps are all included in the price.

Certifications: **CE EMC ACS HACCP** 

Safety Transformer  (230Vac/5Vdc)

Up-down control rod and drain/pop-up stopper are supplied on request.



Recommended for:



Residential



Catering



Hospitality

Overview:

Improve life with intelligence and good taste. This is the prerogative of MiniUno 32, a wall mounted electronic tap with an extremely minimal line. Its strong points are superb practicality and great adaptability promoted above all by a large number of models, with spouts available in many formats.

Versions Available:

With built-in mixer.

For cold or pre-mixed water.

With mixer inside the technical area.

Power Available:

3 AA 1.5 V alkaline batteries.

230Vac - 5Vdc safety transformer.

Pluses:

Photocell activation.

Water saving up to 80%.

Hygiene and wellbeing.

Easy to use.

Long battery life.

Wide range of sizes and versions.

100% Made in Italy.

Recommended for:

Public



Hospitality



Features:

- DMP Infrared System photocell sensors, scratch proof and protected against calcium deposits
- Fully waterproof resined electronic circuit
- The installation must be carried out inside the appropriate technical area (**FIG. 1 below and the assembly diagram on page 95**)
- Chrome-plated vandal-proof brass body
- Also available with mixer (**FIG. 2**)
- Mounting at minimum 27 mm from the sink (**FIG. 3**)
- DMP software programmed microchip for perfect function control
- Optimized functions for a long life of the alkaline batteries
- Autonomy of the batteries: 4-year battery life with 200 activations per day
- Low battery warning: a led in the sensors blinking twice every six seconds indicates that the batteries still have approx. 3 months autonomy
- Batteries easy to change and readily available (FIG. 3)
- Fully waterproof battery case
- Function for flood and consumption protection: the DMP shut-off timer stops the water flow after 90 seconds of continuous use
- Optimized water consumption with limiter at 6 l/min. Optional: limiter at 3 l/min
- Solenoid valve with triple, stainless steel and anti-impurities filter

- Shut-off valves inside the recessed box, equipped with stainless steel, anti-impurities 0.2 mm mesh filters

Technical Specifications:

- AA 1.5 V alkaline batteries
- Electronic circuit: 4.5 V, manufactured in compliance with CEI EN 55014-1/-2 (EMC) requirements
- Solenoid valve: 3 V
- Safety transformer: 230Vac - 5Vdc, IMQ approved and manufactured in compliance with CEI EN 61558-1/-2-6 requirements
- IP65 electrical part protection grade
- Adjustable sensors' range of action: 8 - 35 cm
- Stop taps with non-return valves
- Water pressure: 0.4 - 10 bar
- Pipe fittings: 1/2 G

Package Contents:

- Electronic tap MiniUno 32
- DMP fast connection flexible hoses
- DMP original stop taps
- Installation kit
- Instruction manual
- Battery case with 3 alkaline batteries
or
- DMP safety transformer

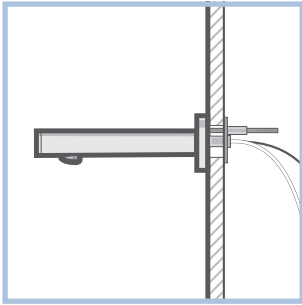

FIG. 1

The designer or installer must ascertain there is enough space for a technical area (p. 95) where the mechanical and electronic parts are to be installed.

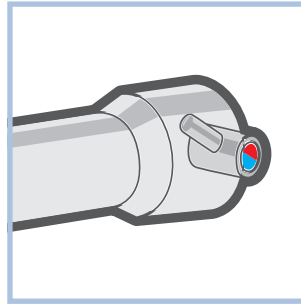

FIG. 2

Once the installation in the technical area is carried out, all MiniUnoMix 32 models shall be fitted with a water adjusting mixer.

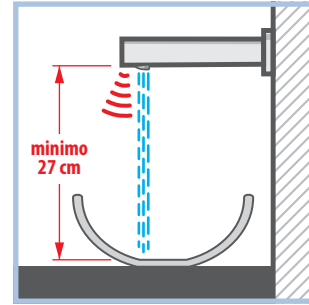

FIG. 3

In order to offer users the most comfortable experience, DMP recommends MiniUno 32 is installed at a minimum distance of 27cm from the bottom of the washbasin.

MiniUnoMix 32200 BT



85506 Chrome

With built-in mixer
 Power: 3x1.5V AA alkaline batteries
 Package weight: Kg. 3.800
 Availability: 10 business days
 Mounting in technical area
 2 inlets: 1/2 G

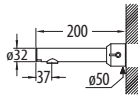

MiniUnoMix 32200



25506 Chrome

With built-in mixer
 Power: 5 Vdc transformer
 Package weight: Kg. 3.950
 Availability: 10 business days
 Mounting in technical area
 2 inlets: 1/2 G

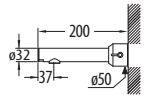

MiniUno 32200 BT



84506 Chrome

For cold or pre-mixed water
 Power: 3x1.5V AA alkaline batteries
 Package weight: Kg. 2.000
 Availability: 6 business days
 Mounting in technical area
 1 inlet: 1/2 G

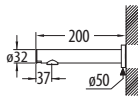

MiniUno 32200



24506 Chrome

For cold or pre-mixed water
 Power: 5 Vdc transformer
 Package weight: Kg. 2.100
 Availability: 6 business days
 Mounting in technical area
 1 inlet: 1/2 G

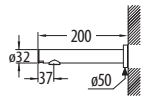

MiniUno 32 MS 200 BT



85606 Chrome

With built-in mixer inside the technical area*
 Power: 3x1.5V AA alkaline batteries
 Package weight: Kg. 2.650
 Availability: 6 business days
 Mounting in technical area
 2 inlets: 1/2 G

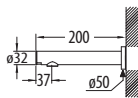

MiniUno 32 MS 200



25606 Chrome

With built-in mixer inside the technical area*
 Power: 5 Vdc transformer
 Package weight: Kg. 2.750
 Availability: 6 business days
 Mounting in technical area
 2 inlets: 1/2 G

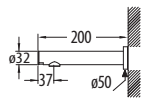

* The mixer handle can be blocked once the temperature is set.

* The mixer handle can be blocked once the temperature is set.

IMPORTANT

All models on this page can be installed only if a specific technical area is present on the system. Strictly follow indications on the diagram.

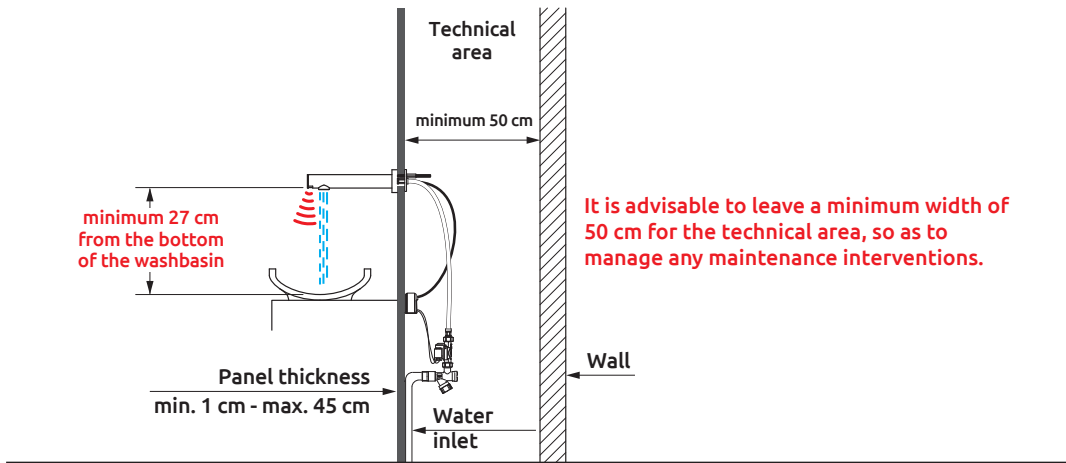

Transformers, batteries and accessories are all included in the price.

Certifications: **CE EMC ACS HACCP** Safety Transformer (230Vac/5Vdc)

Overview:

If you are looking for a practical and functional solution to the requirements of public and work places, Speedy is the ideal choice. Versatile and complete, from time to time it has different proportions, thanks to a very wide range of models. Its external plate and support frame as well as concealed tamper-proof screws are made of stainless steel. The spout is in chrome-plated brass.

Versions Available:

With built-in mixer.

For cold or pre-mixed water.

Recessed or external chassis.

Power Available:

3 AA 1.5 V alkaline batteries.

230Vac - 5Vdc safety transformer.

Pluses:

Photocell activation.

Water saving up to 80%.

Hygiene and wellbeing.

Easy to use.

Long battery life.

Wide range of sizes and versions.

Concealed vandal-proof screws.

Manual mode operations.

100% Made in Italy.

Recommended for:

Industry



Public



Health



Features:

- DMP Infrared System photocell sensors, scratch proof and protected against calcium deposits
- Fully waterproof resined electronic circuit
- External glossy stainless steel plate (FIG. 1)
- DMP software programmed microchip for perfect function control
- Optimized functions for a long life of the alkaline batteries
- Autonomy of the batteries: 4-year battery life with 200 activations per day
- Low battery warning: a led in the sensors blinking twice every six seconds indicates that the batteries still have approx. 3 months autonomy
- Batteries easy to change and readily available (FIG. 2)
- Fully waterproof battery case
- Function for flood and consumption protection: the DMP shut-off timer stops the water flow after 90 seconds of continuous use
- Solenoid valve with triple, stainless steel and anti-impurities filter
- Shut-off valves inside the recessed box, equipped with stainless steel, anti-impurities 0.2 mm mesh filters and water flow regulator
- Spout available in seven sizes
- Manual operation device (mod. SPEEDY 300, SPEEDYMIX 300) (FIG. 3)

Technical Specifications:

- AA 1.5 V alkaline batteries
- Electronic circuit: 4.5 V, manufactured in compliance with CEI EN 55014-1/-2 (EMC) requirements
- Solenoid valve: 3 V
- Safety transformer: 230Vac - 5Vdc, IMQ approved and manufactured in compliance with CEI EN 61558-1/-2-6 requirements
- IP65 electrical part protection grade
- Adjustable sensors' range of action: 8 - 35 cm
- Stop taps with non-return valves
- Water pressure: 0.4 - 10 bar
- Pipe fittings: 1/2 G

Package Contents:

- Electronic tap Speedy
- Recessed or external case
- DMP fast connection flexible hoses
- DMP original stop taps
- Installation kit
- Instruction manual
- Battery case with 3 alkaline batteries
- or
- DMP safety transformer

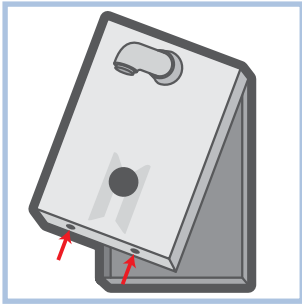

FIG. 1

The SPEEDY fastening system is made up of a stainless steel frame and two concealed tamper-proof screws that guarantee plate hold.

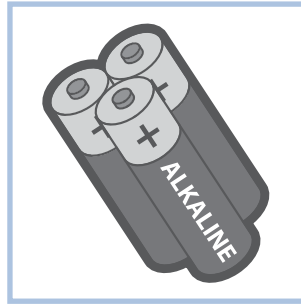

FIG. 2

SPEEDY uses batteries that are readily available: in supermarkets as well as in corner shops. Easy to find, long-lasting.

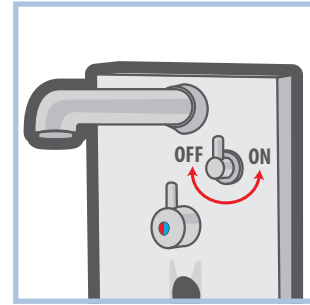

FIG. 3

All 300 series models are equipped with a lever that activates manual tap operations in case of emergency or low battery charge.

Speedymix 200 BT



With built-in mixer
 Power: 3x1.5V AA alkaline batteries
 Package weight: Kg. 3.300 ÷ 3.800
 Availability: 5 business days
 Fixed or swivel spout
 Stainless steel plate

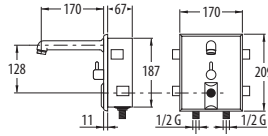

Speedymix 200



With built-in mixer
 Power: 5 Vdc transformer
 Package weight: Kg. 3.400 ÷ 3.900
 Availability: 5 business days
 Fixed or swivel spout
 Stainless steel plate

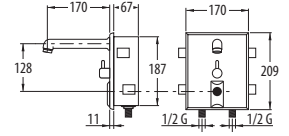

Speedy 200 BT



For cold or pre-mixed water
 Power: 3x1.5V AA alkaline batteries
 Package weight: Kg. 2.600 ÷ 3.100
 Availability: 5 business days
 Fixed or swivel spout
 Stainless steel plate

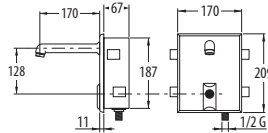

Speedy 200



For cold or pre-mixed water
 Power: 5 Vdc transformer
 Package weight: Kg. 2.700 ÷ 3.200
 Availability: 5 business days
 Fixed or swivel spout
 Stainless steel plate

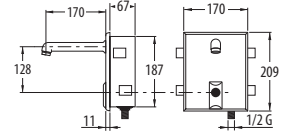

Speedymix 300 BT



With built-in mixer
 Power: 3x1.5V AA alkaline batteries
 Package weight: Kg. 3.500 ÷ 3.900
 Availability: 5 business days
 Fixed or swivel spout
 Stainless steel plate
 With manual mode function

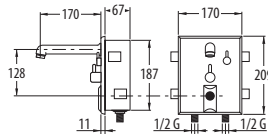

Speedymix 300



With built-in mixer
 Power: 5 Vdc transformer
 Package weight: Kg. 3.600 ÷ 4.000
 Availability: 5 business days
 Fixed or swivel spout
 Stainless steel plate
 With manual mode function

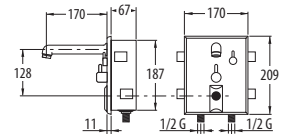

Speedy 300 BT



For cold or pre-mixed water
 Power: 3x1.5V AA alkaline batteries
 Package weight: Kg. 2.800 ÷ 3.200
 Availability: 5 business days
 Fixed or swivel spout
 Stainless steel plate
 With manual mode function

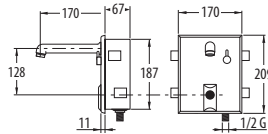

Speedy 300



For cold or pre-mixed water
 Power: 5 Vdc transformer
 Package weight: Kg. 2.900 ÷ 3.300
 Availability: 5 business days
 Fixed or swivel spout
 Stainless steel plate
 With manual mode function

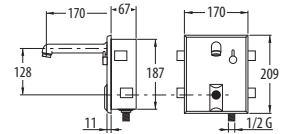

Transformers, batteries and accessories are all included in the price.

Certifications: **CE EMC HACCP** Safety Transformer (230Vac/5Vdc)

The recessed boxes can be supplied in advance, on demand.

7 spout sizes available

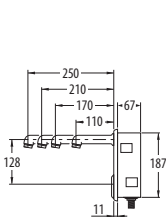

FIXED SPOUTS

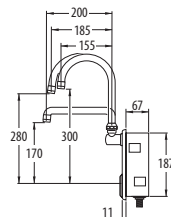

SWIVEL SPOUTS

Also available with external chassis

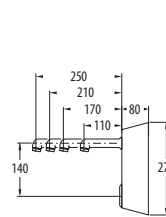

FIXED SPOUTS

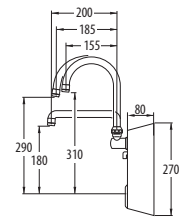

SWIVEL SPOUTS

The **Speedy** line includes as many as **112 models** so as to fulfill customers' and retailers' requirements. All details, codes and features of models are present in **DMP Electronics Price List**.

Overview:

Speedymix Comp is a product specifically suited for medical structures since it includes all the quality, function and technology features required for this sector. Available in four models it flexibly adapts to various plumbing system requirements. It also comes with a continuous water flow button and manual emergency operations device.

Versions Available:

Long or short spout.
Standard or American interaxis
(all with built-in mixer)

Power Available:

2 AA 1.5 V alkaline batteries.

Pluses:

Photocell activation.
Water saving up to 80%.
Hygiene and wellbeing.
Easy to use.
Long battery life.
Button for continuous flow or stop flow mode.
Emergency button.
Suitable for all installation standards.
100% Made in Italy.

Recommended for:

Health



Industry



Catering



Features:

- DMP Infrared System photocell sensors, scratch proof and protected against calcium deposits
- Fully waterproof resined electronic circuit
- Chrome-plated brass body, with swivel spout
- DMP software programmed microchip for perfect function control
- Optimized functions for a long life of the alkaline batteries
- Autonomy of the batteries: 4-year battery life with 200 activations per day
- Low battery warning led
- Batteries easy to change and readily available (**FIG. 1**)
- Fully waterproof battery case
- Function for flood and consumption protection: the DMP shut-off timer stops the water flow after 90 seconds of continuous use
- Solenoid valve with triple, stainless steel and anti-impurities filter
- Stainless steel eccentrics and anti-impurities 0.2 mm mesh filters
- Water temperature and flow regulation by ceramic disk mixer
- Continuous water flow mode dell'acqua (**FIG. 2**)
- Function for manual (**FIG. 3**)
- Interaxial water inlets distance: from 135mm to 165mm in Speedymix Comp 180 BT and 250 BT

models; from 188mm to 218mm in Speedymix Comp 880 BT and 850 BT models

Technical Specifications:

- AA 1.5 V alkaline batteries
- Electronic circuit: 3 V, manufactured in compliance with CEI EN 55014-1/-2 (EMC) requirements
- Solenoid valve: 3 V
- IP65 electrical part protection grade
- Adjustable sensors' range of action: da 5 a 25 cm
- Stop taps with non-return valves
- Water pressure: 0.4 - 10 bar
- Pipe fittings: 1/2 G

Package Contents:

- Electronic tap Speedymix Comp
- Accessories and washers
- Installation kit
- Instruction manual
- Battery case with 2 alkaline batteries

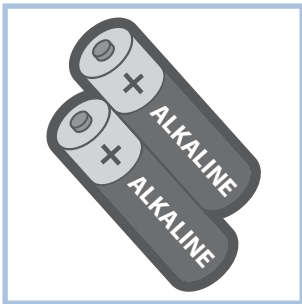

FIG. 1

Speedymix Comp uses batteries that are readily available: in supermarkets as well as in corner shops. Easy to find, long-lasting.

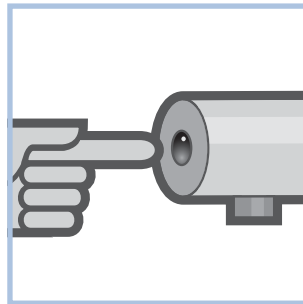

FIG. 2

Press the SPEEDYMIXCOMP multi-function button for 1 second to activate continuous flow mode. Press the button again to stop the flow.

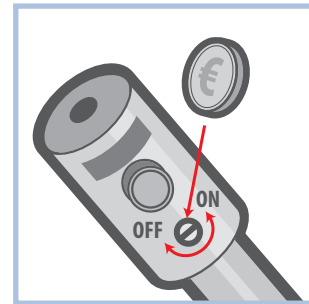

FIG. 3

Rotate the screw counter-clockwise to switch Speedymix Comp to manual mode. The mixer lever is used for on and off functions.

Speedymix Comp 280 BT



73726 Chrome

With ceramic disk mixer
 Power: 2x1.5V AA alkaline batteries
 Package weight: Kg. 3.550
 Availability: 5 business days
 With manual mode function
 With multifunction button
 Swivel spout

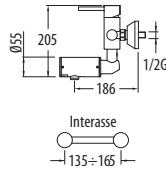

Speedymix Comp 45350 BT



73747 Chrome

With ceramic disk mixer
 Power: 2x1.5V AA alkaline batteries
 Package weight: Kg. 3.350
 Availability: 5 business days
 With manual mode function
 With multifunction button
 Swivel spout

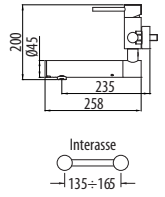

Speedymix Comp 880 BT



73756 Chrome

With ceramic disk mixer
 Power: 2x1.5V AA alkaline batteries
 Package weight: Kg. 3.700
 Availability: 5 business days
 With manual mode function
 American interaxis
 With multifunction button
 Swivel spout

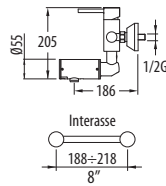

Speedymix Comp 45850 BT



73777 Chrome

With ceramic disk mixer
 Power: 2x1.5V AA alkaline batteries
 Package weight: Kg. 3.500
 Availability: 5 business days
 With manual mode function
 American interaxis
 With multifunction button
 Swivel spout

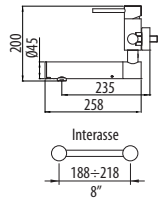

Batteries, stop taps and accessories are all included in the price.

Certifications: **CE EMC ACS HACCP D.M.174**

Overview:

One for all, that is the passepartout electronic tap. As a matter of fact, with just a few simple operations the old button-operated wall tap will be replaced by the new technological Uno. Inside, all the best of DMP research: simplicity of use, hygiene and environment protection, energy saving, for a rational and intelligent use of water resources.

Versions Available:

With built-in mixer.

For cold or pre-mixed water.

With mixer inside the technical area.

Power Available:

2 AA 1.5 V alkaline batteries.

Pluses:

Photocell activation.

Water saving up to 80%.

Hygiene and wellbeing.

Easy to use.

Long battery life.

Easy installation in few minutes.

100% Made in Italy.

Recommended for:

Public



Industry



Features:

- DMP photocell sensors, made of scratchproof and calcium resistant material
- Fully waterproof resined electronic circuit
- Chrome-plated brass body, constructed with specific vandal-proof criteria
- Installation on pre-existing devices (battery operated Uno BT model) (**FIG. 1**)
- DMP software programmed microchip for perfect function control
- Optimized functions for a long life of the alkaline batteries
- Autonomy of the batteries: 4-year battery life with 200 activations per day
- Low battery warning: a led in the sensors blinking twice every six seconds indicates that the batteries still have approx. 3 months autonomy
- Batteries easy to change and readily available (**FIG. 2**)
- Fully waterproof battery case
- Function for flood and consumption protection: the DMP shut-off timer stops the water flow after 90 seconds of continuous use
- From 1mm to 45mm thick wall mount with technical area for Unomix models with mixers (**FIG. 3**)
- Available spout lengths: 126 mm and 214 mm (for Uno models), 152 mm and 240 mm (for UnoMix models)

Technical Specifications:

- AA 1.5 V alkaline batteries
- Electronic circuit: 3 V, manufactured in compliance with CEI EN 55014-1/-2 (EMC) requirements
- Solenoid valve: 2 V
- IP65 electrical part protection grade
- Adjustable sensors' range of action: 8 - 35 cm
- Stop taps with non-return valves
- Water pressure: 0.4 - 10 bar
- Pipe fittings: 1/2 G

Package Contents:

- Electronic tap Uno
- DMP fast connection flexible hoses
- DMP original stop taps
- Installation kit
- Instruction manual
- Battery case with 2 alkaline batteries

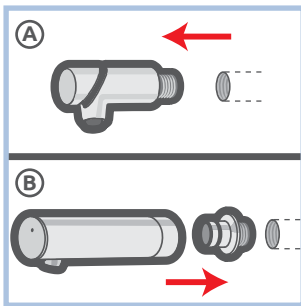

FIG. 1

Updating without modifying the system: with Uno you can. Just remove the old button-operated tap and install the new Uno BT.

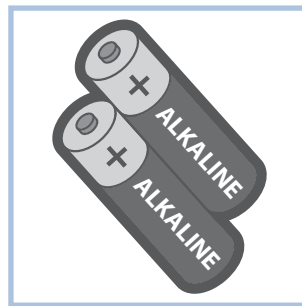

FIG. 2

Uno uses batteries that are readily available: in supermarkets as well as in corner shops. Easy to find, long-lasting.

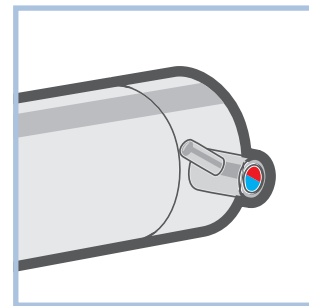

FIG. 3

The UnoMix models are equipped with built-in mixers, a plus for sites that put comfort first.

Uno 12 Fr BT

83516 Chrome



For cold or pre-mixed water
Power: 2x1.5V AA alkaline batteries
Package weight: Kg. 1.600
Availability: 6 business days
1 inlet: 1/2 G

Installation with rapid fitting joint

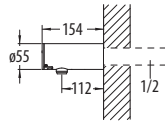

Uno 21 Fr BT

82516 Chrome



For cold or pre-mixed water
Power: 2x1.5V AA alkaline batteries
Package weight: Kg. 1.750
Availability: 6 business days
1 inlet: 1/2 G

Installation with rapid fitting joint

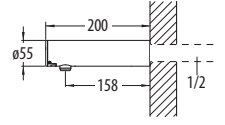

UnoMix 15 BT

83606 Chrome



With built-in mixer
Power: 2x1.5V AA alkaline batteries
Package weight: Kg. 2.450
Availability: 15 business days
2 inlets: 1/2 G

Installation in technical area

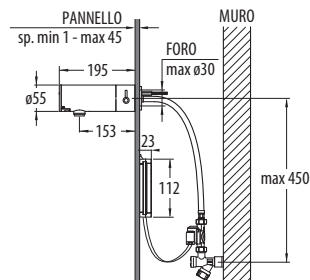

UnoMix 24 BT

82606 Chrome



With built-in mixer
Power: 2x1.5V AA alkaline batteries
Package weight: Kg. 2.600
Availability: 15 business days
2 inlets: 1/2 G

Installation in technical area

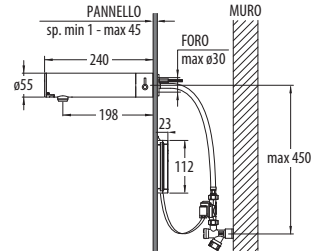

IMPORTANT

All UnoMix 15 BT and UnoMix 24 BT models can be installed only if a specific technical area is present on the system. Strictly follow indications in the diagram.

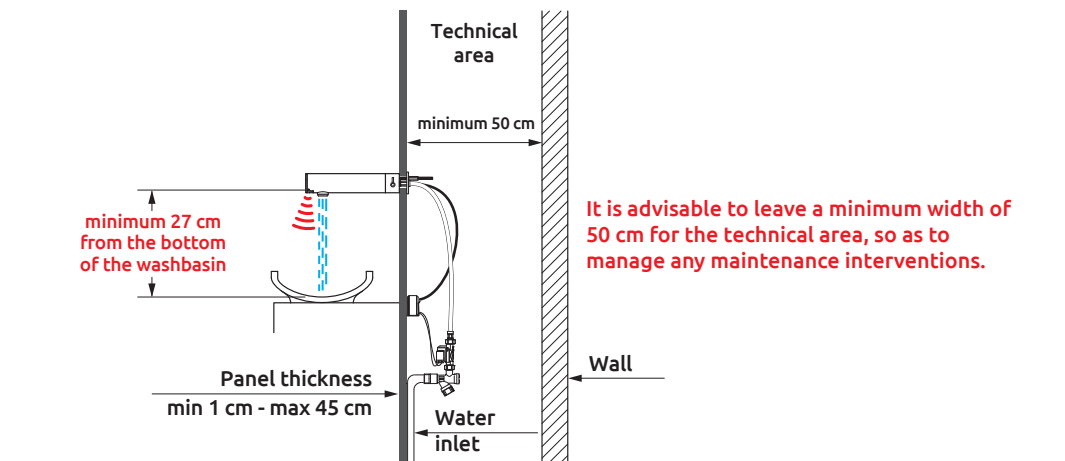

Batteries, flexible hoses, stop taps and accessories are included in the price.

Certifications: **CE EMC HACCP D.M.174**

Overview:

Joy brings elegance and comfort to modern kitchens, with the technological plus offered by the mouse-shaped body that hides all the electronic elements and controls the tap functions. In addition to technological significance, this detail makes the tap extremely easy to install: in fact the operator shall only have to connect the stopcocks and secure Joy to the sink, like a normal kitchen tap. The practical mobile arm makes it suitable to twin-bowl sinks.

Versions Available:

With 215 mm swivel spout.
With 243 mm swivel spout.
(both with built-in mixer)

Power Available:

1 3,6 V lithium battery.

Pluses:

Photocell activation.
Water saving up to 80%.
Easiness in use and installation.
Long battery life.
Button for continuous flow or stop flow mode.
Manual mode operations.
100% Made in Italy.

Recommended for:

Residential



Features:

- DMP photocell sensors, made of scratchproof and calcium resistant material
- Fully waterproof resined electronic circuit
- Chrome-plated brass body containing electronics, battery and solenoid valve
- Stainless steel installation kit
- DMP software programmed microchip for perfect function control
- Optimized functions for a long life of the alkaline batteries
- Autonomy of the batteries: 4-year battery life with 200 activations per day
- Low battery warning: a led in the sensors blinking twice every six seconds indicates that the batteries still have approx. 3 months autonomy
- Batteries easy to change and readily available
- Fully waterproof battery case
- Function for flood and consumption protection: the DMP shut-off timer stops the water flow after 3 minutes of continuous use (**FIG. 1**)
- Water temperature and flow regulation by ceramic disk mixer
- Continuous water flow mode (**FIG. 2**)
- Function for manual mode (**FIG. 3**)
- Solenoid valve with double, stainless steel and anti-impurities filter

- Shut-off valves inside the recessed box, equipped with stainless steel, anti-impurities 0.2 mm mesh filters
- Two spout lengths available: 215 mm (Joy 16 BT) and 243 mm (Joy 19 BT)
- 360° swivel spout

Technical Specifications:

- Lithium battery: 3.6 V
- Electronic circuit: 3 V, manufactured in compliance with CEI EN 55014-1/2 (EMC) requirements
- Solenoid valve: 3 V
- IP65 electrical part protection grade
- Adjustable sensors' range of action: 5 - 25 cm
- Stop taps with non-return valves
- Water pressure: 0.4 - 10 bar
- Pipe fittings: 1/2 G

Package Contents:

- Electronic tap Joy
- DMP fast connection flexible hoses
- DMP original stop taps
- Installation kit
- Instruction manual
- Battery case with 1 lithium battery



FIG. 1

The shut-off timer is a flood protection device that stops the water flow after one and a half minutes of continuous use. Maximum home safety.



FIG. 2

Press the Joy multi-function button for 1 second to activate continuous flow mode. Press the button again to stop flow.

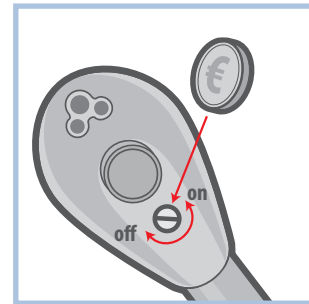

FIG. 3

Rotate the screw counter-clockwise to switch JOY to manual mode. The mixer lever is used for on and off functions.

Joy 16 BT



76776 Chrome

With ceramic disk mixer
 Power: 1x3.6 V lithium battery
 Package weight: Kg. 2.850
 Availability: 3 business days
 With manual mode function
 With continuous water flow button
 Swivel spout 360°

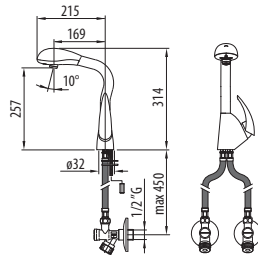

Joy 19 BT



76756 Chrome

With ceramic disk mixer
 Power: 1x3.6 V lithium battery
 Package weight: Kg. 2.900
 Availability: 3 business days
 With manual mode function
 With continuous water flow button
 Swivel spout 360°

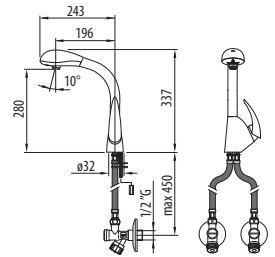

Batteries, flexible hoses, stop taps and accessories are all included in the price.

Certifications: **CE EMC HACCP**

Overview:

A tap originally designed for large restaurant kitchens, Oceanus has been redesigned to leave its mark also in the home. The mobile arm is especially suited for large twin-bowl sinks. The electronic and mechanical parts are all included in the cylinder head so that the installation technician only has to connect the stopcocks and secure Oceanus to the sink for immediate operation.

Versions Available:

With 239 mm, 195 mm or 152 mm swivel spout.

With 152 mm fixed spout.

(all with built-in mixer)

Power Available:

2 AA 1.5 V alkaline batteries.

Pluses:

Photocell activation.

Water saving up to 80%.

Easiness in use and installation.

Long battery life.

Button for continuous flow or stop flow mode.

Manual mode operations.

100% Made in Italy.

Recommended for:

Catering



Residential



Features:

- DMP photocell sensors, made of scratchproof and calcium resistant material
- Fully waterproof resined electronic circuit
- Chrome-plated brass body containing electronics, batteries and solenoid valve
- Stainless steel installation kit
- DMP software programmed microchip for perfect function control
- Optimized functions for a long life of the alkaline batteries
- Autonomy of the batteries: 4-year battery life with 200 activations per day
- Low battery warning: a led in the sensors blinking twice every six seconds indicates that the batteries still have approx. 3 months autonomy
- Batteries easy to change and readily available
- Fully waterproof battery case
- Function for flood and consumption protection: the DMP shut-off timer stops the water flow after 3 ½ minutes of continuous use (**FIG. 1**)
- Water temperature and flow regulation by ceramic disk mixer
- Continuous water flow mode (**FIG. 2**)
- Function for manual mode (**FIG. 3**)
- Solenoid valve with double, stainless steel and anti-impurities filter
- Shut-off valves inside the recessed box,

equipped with stainless steel, anti-impurities 0.2 mm mesh filters

- Three spout lengths available: 232 mm (Oceanus 19 BT), 276 mm (Oceanus 23 BT), 185 mm (Oceanus 15 BT - Oceanus 15-FS BT)
- 360° swivel spout on all models (except Oceanus 15-FS BT)

Technical Specifications:

- AA 1.5 V alkaline batteries
- Electronic circuit: 3 V, manufactured in compliance with CEI EN 55014-1/-2 (EMC) requirements
- Solenoid valve: 2 V
- IP65 electrical part protection grade
- Adjustable sensors' range of action: 5 - 25 cm
- Stop taps with non-return valves
- Water pressure: 0.4 - 10 bar
- Pipe fittings: 1/2 G

Package Contents:

- Electronic tap Oceanus
- DMP fast connection flexible hoses
- DMP original stop taps
- Installation kit
- Instruction manual
- Battery case with 2 alkaline batteries



FIG. 1

The shut-off timer is a flood protection device that stops the water flow after one and a half minutes of continuous use. Maximum home safety.

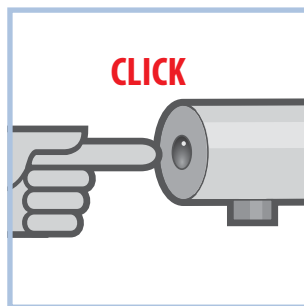

FIG. 2

Press the Oceanus multi-function button for 1 second to activate continuous flow mode. Press the button again to stop flow.

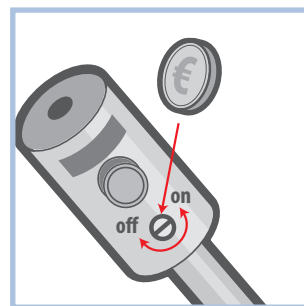

FIG. 3

Rotate the screw counter-clockwise to switch Oceanus to manual mode. The mixer lever is used for on and off functions.

Oceanus 19 BT



76006 Chrome

With ceramic disk mixer
 Power: 2x1.5V AA alkaline batteries
 Package weight: Kg. 3.700
 Availability: 3 business days
 With manual mode function
 With continuous water flow button
Swivel spout 360°

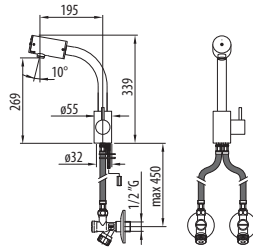

Oceanus 23 BT



76016 Chrome

With ceramic disk mixer
 Power: 2x1.5V AA alkaline batteries
 Package weight: Kg. 3.800
 Availability: 3 business days
 With manual mode function
 With continuous water flow button
Swivel spout 360°

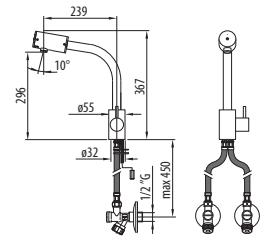

Oceanus 15 BT



76036 Chrome

With ceramic disk mixer
 Power: 2x1.5V AA alkaline batteries
 Package weight: Kg. 3.500
 Availability: 3 business days
 With manual mode function
 With continuous water flow button
Swivel spout 360°

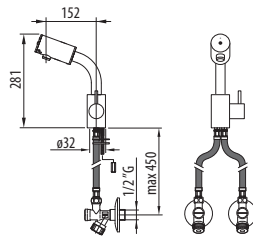

Oceanus 15-FS BT



76026 Chrome

With ceramic disk mixer
 Power: 2x1.5V AA alkaline batteries
 Package weight: Kg. 3.500
 Availability: 3 business days
 With manual mode function
 With continuous water flow button
Fixed spout

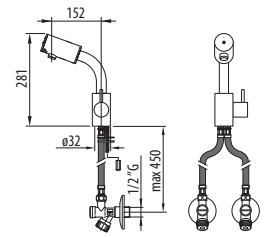

Batteries, flexible hoses, stop taps and accessories are all included in the price.

Certifications: **CE EMC HACCP**

Overview:

SANIKIT is a technological washbasin, better described as a hygienic set for the public and hospitals. The most obvious element is the beautiful stainless steel basin. Above it, orderly set on the built-in panel, the electronic taps, thermostatic mixer and electronic soap dispenser are already installed. The range includes various sizes and versions.

Sanikit 111 1 Station Washbasin

16811 AISI 304 Stainless steel

Weight: 51 kg
Availability: 35 business days
Accessories
1 electronic tap
1 soap dispenser
1 thermostat mixer
With rounded edges

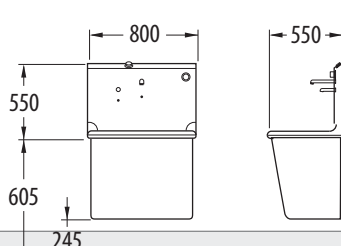

Sanikit 211 2 Station Washbasin

16812 AISI 304 Stainless steel

Weight: 62 kg
Availability: 35 business days
Accessories
2 electronic taps
1 soap dispenser
1 thermostat mixer
With rounded edges

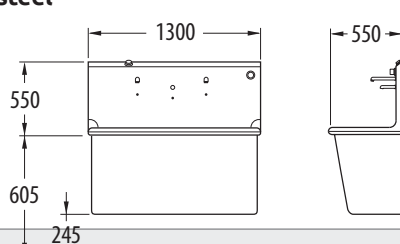

Sanikit 321 3 Station Washbasin

16819 AISI 304 Stainless steel

Weight: 80 kg
Availability: 35 business days
Accessories
3 electronic taps
2 soap dispensers
1 thermostat mixer
With rounded edges

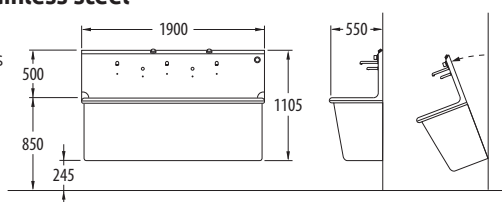

- Peristaltic pump
- Tilt basin opening system
- All electronic parts are constructed with IP65 protection grade

Certifications:  **EMC HACCP**  Safety Transformer  (230Vac/9Vdc)



Overview:

Sanitech is a hygienic set that includes a stainless steel washbasin and electronic DMP model tap. Extremely adaptable to installation needs, Sanitech comes in numerous sizes and versions and two formats, with round or square basin.

STK500 mix



- 20621 STK500 with Class 20 M BT** (page 41)
- 20611 STK500 with Compactomix BT** (page 61)
- 20651 STK500 with Diamix 200 BT** (page 65)
- 20681 STK500 with Ecomix Plus 113 BT** (page 69)
- 20671 STK500 with Settemix BT** (page 73)
- 20682 STK500 with Arcomix Plus 135 BT**(page 81)
- 20661 STK500 with Oceanus 15-FS BT** (page 117)

Features:

With stainless steel square basin
Tap with built-in mixer
Package weight: 12 kg
Power: 3 1.5 V alkaline batteries (AA)
Availability: 10 business days

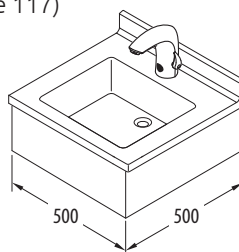

STK500



- 20622 STK500 with Class 10 M BT** (page 41)
- 20652 STK500 with Dia 1200 BT** (page 65)
- 20683 STK500 with Eco Plus 113 BT** (page 69)
- 20671 STK500 with Sette BT** (page 73)
- 20684 STK500 with Arco Plus 135 BT** (page 81)

Features:

With stainless steel square basin
Cold water or pre-mixed tap
Package weight: 11 kg
Power: 3 1.5 V alkaline batteries (AA)
Availability: 10 business days

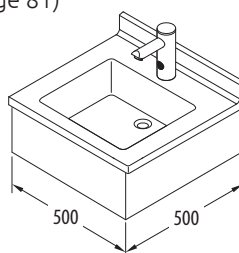

The Sanitech line also includes a version with round basin: STK400. All details, codes and features can be found in the **DMP Electronics Price List**.

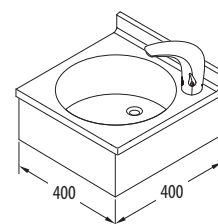

Batteries, flexible hoses, stop taps and accessories are included in the price.

Certifications:  **EMC HACCP D.M.174**



Overview:

Sanisoap Inox is an electronic liquid soap or disinfectant dispenser. The line and choice of materials, especially steel, give it resistance and aesthetic worth making it ideal for hospitality and public establishments. SaniPro Inox, with peristaltic pump, includes adjustable dose. This function is ideal in the health-hospital field where above average soap or disinfectant doses are required. Sanisoap Inox is easy to install and comes with safety key for tank opening.

Versions Available:

With standard dose.

With dose spray.

With peristaltic pump and adjustable dose.

Power Available:

6 AA 1.5 V alkaline batteries.

230 Vac – 9Vdc safety transformer.

Pluses:

Hygiene and wellbeing.

Long lasting.

Easy to use.

Easy to install.

Large tank capacity.

Can be combined with hand dryers and tap.

Recommended for:

Health



Public



Catering



Institutions



Industry



DMP recommends **Sanisoap Inox** in combination with the electronic tap **Eco plus** (page 64) and with the electronic hand dryer **Turbo** (page 130). The three articles form the **Chrome Kit** (pages 12 and 13)

Features:

- DMP Infrared System photocell sensors, scratch proof and protected against calcium deposits
- Fully waterproof resined electronic circuit
- Polished stainless steel body
- DMP software programmed microchip for perfect function control
- Optimized functions for a long life of the alkaline batteries
- Autonomy of the batteries: 2-year battery life with 200 activations per day
- Batteries easy to change and readily available
- Inside battery case
- Low battery warning led
- Locked cover with metallic key (Sanisoap Inox and SaniPro) **(FIG. 1)**
- Tank: 1 liter
- Product level inspection window
- Adjustable soap dose: 1 ml - 5.5 ml (SaniPro 2) **(FIG. 2)**
- Adjustable sensors' range of action **(FIG. 3)**

Technical Specifications:

- AA 1.5 V alkaline batteries
- Electronic circuit: 9 V, manufactured in compliance with CEI EN 61558-1/-2-6 requirements
- IP44 class protected electrical parts
- Safety Transformer: CE, manufactured in compliance with CEI EN 61558-1/-2-6 requirements
- Sensors' range of action: 5 - 25 cm
- Peristaltic pump: 6V (SaniPro 2)

Package Contents:

- Soap dispenser Sanisoap Inox or SaniPro
- Installation kit
- Instruction manual
- Battery case with 6 alkaline batteries
or
- DMP safety transformer

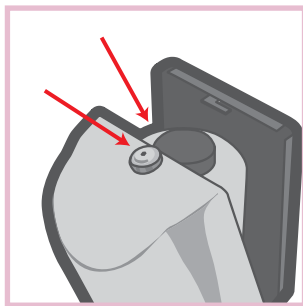

FIG. 1

To prevent vandalism, Sanisoap Inox and SaniPro are equipped with a safety lock that can be opened with the key supplied.

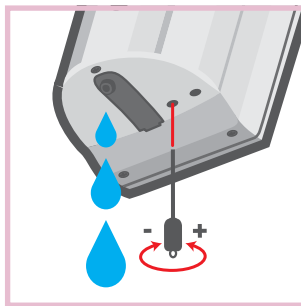

FIG. 2

Soap or disinfectant dosages can be adjusted in the SaniPro2 model from a minimum of 1 ml to a maximum of 5.5 ml. This function is useful in doctors' offices and hospitals.

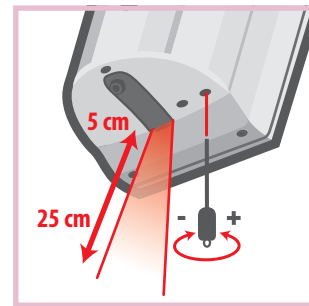

FIG. 3

To adjust sensor range, simply regulate the trimmer with a screwdriver following the arrows. The range varies from 5 to 25 cm.

Sanisoap Inox BT



- 64223 White**
- 64206 Chrome**
- 64213 Chrome Satin**
- 64212 Bronze**

Availability: 5 business days
 Availability: 2 business days
 Availability: 5 business days
 Availability: 10 business days

Power: 6 AA 1.5 V alkaline batteries
 Package weight: Kg. 1.700
 Tank: 1 liter
 Dispenses liquid dose
 Standard motor
 Fixed dose

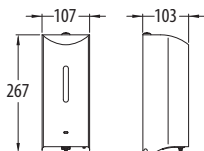

Sanisoap Inox



- 34223 White**
- 34206 Chrome**
- 34213 Chrome Satin**
- 34212 Bronze**

Availability: 5 business days
 Availability: 2 business days
 Availability: 5 business days
 Availability: 10 business days

Power: 9Vdc transformer
 Package weight: Kg. 1.800
 Tank: 1 liter
 Dispenses liquid dose
 Standard motor
 Fixed dose

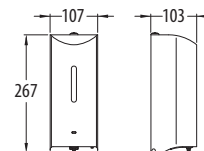

Sanisoap Inox Spray



- 34243 White**
- 34226 Chrome**
- 34233 Chrome Satin**
- 34232 Bronze**

Availability: 5 business days
 Availability: 2 business days
 Availability: 5 business days
 Availability: 10 business days

Power: 9Vdc transformer
 Package weight: Kg. 1.800
 Tank: 1 liter
Spray dispenser for liquid doses
 Standard motor
 Fixed dose

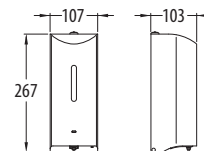

SaniPro-2 Inox



- 34543 White**
- 34526 Chrome**
- 34533 Chrome Satin**
- 34512 Bronze**

Availability: 5 business days
 Availability: 2 business days
 Availability: 5 business days
 Availability: 10 business days

Power: 9Vdc transformer
 Package weight: Kg. 1.930
 Tank: 1 liter
 Dispenses liquid dose
 Peristaltic pump
 Adjustable dose
 Designed for hospital use

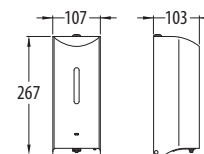

4 colors available



White



Chrome



Chrome Satin



Bronze

Transformers, batteries and accessories are all included in the price.

Certifications: **CE EMC D.M.174** Safety Transfomer (230Vac/9Vdc)

Overview:

The minimal design, reduced weight and polished finish are the features that make Sanisoap Abs the ideal choice for public and hospitality establishments. Installation is easy and immediate, facilitated by the dimensions in the electronic dispenser body. Standard or spray soap dose dispenser according to the selected model. Body opening is guaranteed by a supplied safety key while the tank, made of translucent ABS, is removable to facilitate soap filling.

Versions Available:

With standard dose dispenser.

With spray dose dispenser.

Power Available:

6 AA 1.5 V alkaline batteries.

230 Vac – 9Vdc safety transformer.

Pluses:

Hygiene and wellbeing.

Long lasting.

Easy to use.

Easy to install.

Removable tank.

Can be combined with DMP hand dryers and taps.

Recommended for:

Catering



Public



Institutions



DMP recommends **Sanisoap Abs** in combination with the electronic tap **Class Abs** (page 40) and with the electronic hand dryer **Aria** (page 134). The three articles form the **White Kit** (pages 14 and 15)

Features:

- DMP Infrared System photocell sensors, scratch proof and protected against calcium deposits
- Fully waterproof resined electronic circuit
- Body made of shockproof white ABS
- DMP software programmed microchip for perfect function control
- Optimized functions for a long life of the alkaline batteries
- Autonomy of the batteries: 2-year battery life with 200 activations per day
- Batteries easy to change and readily available
- Fully waterproof battery case
- Low battery warning led
- Cover key lock (Sanisoap Abs)
- Tank: 1 liter
- Product level inspection window (**FIG. 1**)
- Spray version is also available (**FIG. 2**)

Technical Specifications:

- AA 1.5 V alkaline batteries
- Electronic circuit: 9 V, manufactured in compliance with CEI EN 61558-1/-2-6 requirements
- IP44 class protected electrical parts
- Safety Transformer: CE, manufactured in compliance with CEI EN 61558-1/-2-6 requirements
- Sensors' range of action: 5-25 cm
- Adjustable sensors' range of action (**FIG. 3**)

Package Contents:

- Sanisoap Abs soap dispenser
- Installation kit
- Instruction manual
- Battery case with 6 alkaline batteries
or
- DMP safety transformer



FIG. 1

Thanks to the convenient translucent ABS window on the front of the body, the tank soap level is always under control. Never again out of soap.



FIG. 2

Sanisoap Abs also comes in the spray dispenser version for light disinfectant liquids.

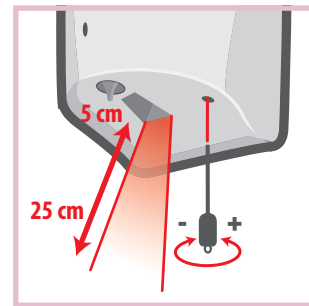

FIG. 3

To adjust sensor range, simply regulate the trimmer with a screwdriver following the arrows. The range varies from 5 to 25 cm.

Sanisoap Abs BT



64203 White

Power: 6 AA 1.5 V alkaline batteries
 Package weight: Kg. 1.130
 Tank: 1 liter
 Dispenses liquid dose
 Standard motor
 Fixed dose

Availability: 5 business days

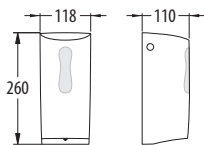

Sanisoap Abs



34203 White

Power: 9Vdc transformer
 Package weight: Kg. 1.280
 Tank: 1 liter
 Dispenses liquid dose
 Standard motor
 Fixed dose

Availability: 5 business days

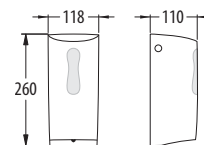

Sanisoap Spray Abs



34263 White

Power: 9Vdc transformer
 Package weight: Kg. 1.280
 Tank: 1 liter
Spray dispenser for liquid doses
 Standard motor
 Fixed dose

Availability: 5 business days

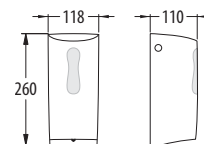

Transformers, batteries and accessories are all included in the price.

Certifications: **CE EMC D.M.174** Safety Transformer (230Vac/9Vdc)

Features:

- Liquid soap dispenser
- Installation directly on the washbasin
- DMP Infrared System photocell sensors, scratch proof and protected against calcium deposits
- Fully waterproof resined electronic circuit
- Chrome-plated brass body
- DMP software programmed microchip for perfect function control
- Two spout lengths: 100 mm and 120 mm
- Tank: 5 liters
- Adjustable soap dose: 1 ml - 6 ml
- Stainless steel case for liquid soap container, electronics and peristaltic pump
- Professional peristaltic pump (long life)
- Product level inspection window on the case

Power:

- Safety Transformer: 230Vac - 10Vac, manufactured in compliance with CEI EN 61558-1/-2-6 requirements

Technical Specifications:

- Electronic circuit: 10 V, manufactured in compliance with CEI EN 61558-1/-2-6 requirements
- IP65 class protected electrical parts
- Safety Transformer: 230 Vac - 10 Vac, manufactured in compliance with CEI EN 61558-1/-2-6 requirements
- Sensors' range of action: 3-12 cm

Package Contents:

- Quary Soap dispenser with case holder
- Installation kit
- Instruction manual
- DMP safety transformer

Quary Soap 120



07716	Chrome	120 mm spout
07736	Chrome	100 mm spout

Power: 10 Vac transformer
 Package weight: Kg. 3.700
 Availability: 10 business days
 Liquid dose dispenser
 Adjustable dose

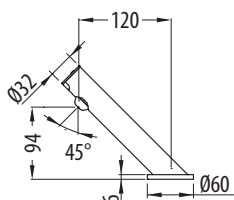

QUARY SOAP 120

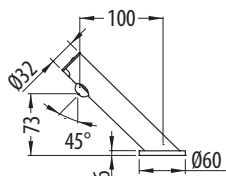

QUARY SOAP 100

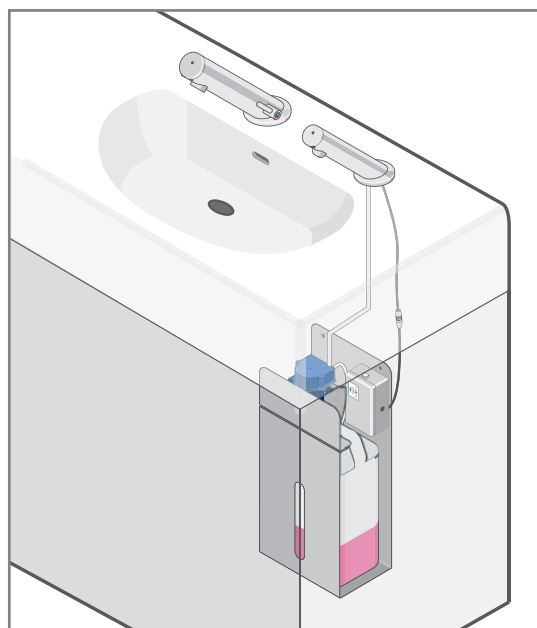



Quary Tap
Electronic Tap

Quary Soap
Soap Dispenser

DMP recommends **Quary Soap** in combination with the electronic tap **Quary Tap** (page 48)

Overview:

We like to think we have added aesthetic worth in a tool that normally only requires practicality, safety and comfort. Turbo has the power of a high performance electronic hand dryer combined with a soft, modern and essential design. This design becomes a furnishing accessory and practical treasure that dries hands in just 20 seconds with a pleasant air flow. The stainless steel vandal-proof body and internal thermal protector guarantee safety.

Colours Available:

White, polished chrome, satin chrome, bronze.

Power Available:

230 V - 50 Hz.

Pluses:

Photocell activation.
Total hygiene.
Long lasting.
Easy to use.
Maximum safety.
Wide range of colours.
Can be combined with DMP dispenser and tap.

Recommended for:

Catering



Public



Institutions



Hospitality



Industry



DMP recommends **Turbo** in combination with the electronic tap **Eco Plus** (page 64) and with the electronic soap dispenser **Sanisoap Inox** (page 120). The three articles form the **Chrome Kit** (pages 12 and 13)

Features:

- Electronic hot air hand dryer, with hand detection activation through DMP photocell sensors
- Electronic circuit protected from humidity
- Polished stainless steel body
- DMP software programmed microchip for perfect function control
- Automatic air stop after 2 minutes of continuous use (**FIG. 1**)
- Vandal-proof body fastening screws (with specific key)
- Self-extinguishing coil
- Aluminium fan
- Rustproof rear sheet metal base and shock absorbing rubbers
- Induction motor (long life) (**FIG. 2**)
- Thermoelectric resistance with built-in thermal protector
- Mains connection possibility with cables in or out of the body

Technical Specifications:

- 20 sec. drying time (**FIG. 3**)
- Total power: 2000W (motor: 250 W)
- Air flow: 220 m³/h - IEC 61591
- IPX1 class protected electrical parts
- Insulation class: I
- CE certification (EN 60335-1)
- Power: 230 V/50 Hz
- Adjustable sensors' range of action: 10 - 30 cm

Package Contents:

- Electronic hand dryer Turbo
- Installation kit
- Instruction manual



FIG. 1

Turbo comes with an internal device that stops operations 2 minutes after continuous use. Truly vandal-proof.

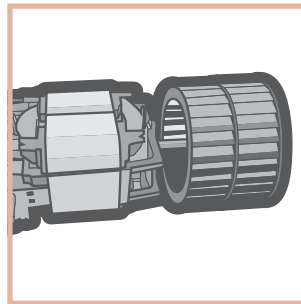

FIG. 2

The long brushes and perfect engineering of internal components guarantee the Turbo manifold motor long life and impeccable operations.

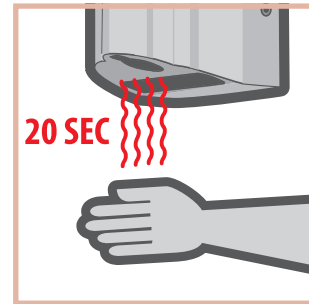

FIG. 3

Thanks to the power of its air jet, Turbo dries hands in just a short period of time: about 20 seconds.

Turbo 2000



- 16923 White**
- 16926 Chrome**
- 16933 Chrome Satin**
- 16912 Bronze**

Availability: 5 business days
 Availability: 2 business days
 Availability: 5 business days
 Availability: 10 business days

Power: 230V/50Hz
 Package weight: Kg. 4.700
 Air: 220m³/h
 Stainless steel body

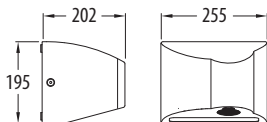

4 colors available



White



Chrome



Chrome satin



Bronze

The accessories are all included in the price.

Certifications: **CE EMC HACCP D.M.174**

Overview:

With its minimal and simple design, Aria is a solution that adapts to every room, thanks to the design neutrality that distinguishes its shape. The advanced technology makes it a high performance and extremely efficient electronic hand dryer: the hot and enveloping air flow dries hands in just 20 seconds. Attention to material resistance is not less important, starting with the ABS shock-proof body. Safety is also guaranteed in the most extreme conditions, thanks to the thermal protector that stops operations at high temperatures.

Power:

230 V - 50 Hz.

Pluses:

Photocell activation.

Total hygiene.

Long lasting.

Easy to use.

Maximum safety.

Can be combined with DMP dispenser and tap.

Recommended for:

Catering



Public



Institutions



Hospitality



DMP recommends **Aria** in combination with the electronic tap **Class Abs** (page 40) and with the electronic soap dispenser **Sanisoap Abs** (page 124). The three articles form the **Kit White** (pages 14 and 15)

Features:

- Electronic hot air hand dryer, with hand detection activation through DMP photocell sensors (**FIG. 1**)
- Fully waterproof resined electronic circuit
- Robust glossy ABS body
- DMP software programmed microchip for perfect function control
- Automatic air stop after 2 minutes of continuous use (**FIG. 2**)
- Concealed vandal-proof body fastening screws (with specific key) (**FIG. 3**)
- Self-extinguishing coil
- Aluminium fan
- Rear sturdy ABS base with shock absorber grooves and rubbers
- Induction motor (long life)
- Thermoelectric resistance with built-in thermal protector
- Mains connection possibility with cables in or out of the body

Technical Specifications:

- 20 sec. drying time
- Total power: 2000W (motor: 250 W)
- Air flow: 220 m³/h - IEC 61591
- IPX4 class protected electrical parts
- Insulation class: II
- CE certification (EN 60335-1)
- Power: 230 V/50 Hz
- Adjustable sensors' range of action: 10 - 30 cm

Package Contents:

- Electronic hand dryer Aria
- Installation kit
- Instruction manual



FIG. 1

Aria is activated by DMP infrared sensors and does not require buttons: maximum hygiene.



FIG. 2

Aria comes with an internal device that stops operations 2 minutes after continuous use. Truly vandal-proof.

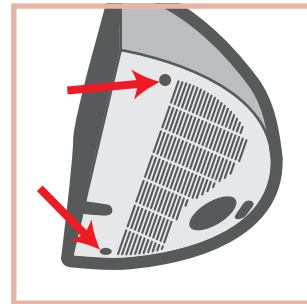

FIG. 3

The durable Aria Abs body is built with safety criteria. Body fastening screws are concealed at the bottom.

Aria**21003 White**

Availability: 3 business days

Power: 230V/50Hz
Package weight: Kg. 3.200
Air: 220m³/h
ABS body

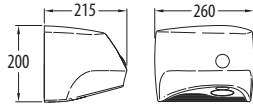

The installation accessories are all included in the price.

Certifications: **CE EMC HACCP D.M.174**

Overview:

Designed to guarantee maximum user safety, PickUp and Jolly are the solutions that offer reassurance while guaranteeing high performance. They are simple to use and automatic: just unhook the nozzle from its housing and hot, enveloping air immediately flows. They are wall-mounted hair dryers, constructed with highly resistant components and are thus ideal for intensive use in hotels, sports centres, pools, camp sites and in all accommodation facilities in general.

Models Available:

PickUp: two speeds.

Jolly: one speed.

(for all models and specifications see pages 140-141).

Power Available:

230 V - 50 Hz.

Pluses:

Total safety.

Automatic activation.

Easy to use.

Long lasting.

Recommended for:

Sport



Holiday



Hospitality



Residential



Features:

- Totally safe hair dryers, with automatic on/off function (**FIG. 1**)
- Inside electronic circuit timer
- DMP software programmed microchip for perfect function control
- 2-speed regulation with selector (PickUp)
- 1-speed fixed regulation (Jolly)
- Flexible braided steel line tube, extensible to 120 cm
- Robust ABS body
- Rear concealed body hook (**FIG. 2**)
- Self-extinguishing coil
- Free rotating nozzle made of burn proof material
- Induction motor
- Thermoelectric resistance with built-in thermal protector
- Mains connection possibility with cables in or out of the body
- Immediate stop possibility when flexible tube falls (PickUp SL) (**FIG. 3**)
- Automatic stop possibility after 15 minutes of continuous use (PickUp TL)
- Immediate stop possibility when flexible tube falls and automatic stop 15 minutes after continuous use (PickUp EL)
- Immediate stop possibility when the flexible tube falls, automatic stop 15 minutes after continuous use, electrical razor socket (230 V - 120 V) with safety transformer (max 10 W) (PickUp XLP)

Technical Specifications:

- Power: 230 V/50 Hz
- Total power: 700W
- IPX0 class protected electrical parts
- Insulation class: II
- CE certification - IMQ (PickUp - see page on models available)
- CE certification (Jolly)

Package Contents:

- Totally safe Pick Up or Jolly hair dryer
- Installation kit
- Instruction manual



FIG. 1

To activate the hair dryer, simply unhook the nozzle and hot air tube from its housing. Additionally, the nozzle freely rotates and is made of burn proof material.

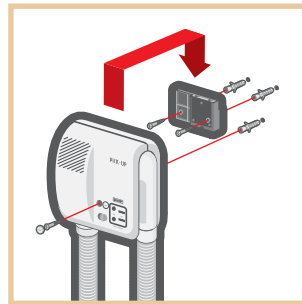

FIG. 2

The mounting system is simple, safe and innovative. Just attach the electric safety hook to the wall with screws and dowels and hang the body, securing the mount with concealed fastening screws.

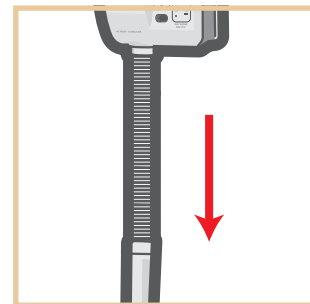

FIG. 3

Air flow immediately stops if the nozzle falls from the housing or is vandalised. This saves electricity and improves safety.

PickUp L

03303 White

2 speeds
 Power: 230V
 Package weight: Kg. 2.200
 Availability: 2/3 business days
 ABS body
 Tube extends up to 120 cm
 Automatic on/off

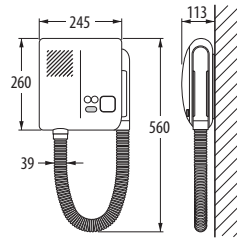

PickUp TL

03703 White

2 speeds
 Power: 230V
 Package weight: Kg. 2.300
 Availability: 2/3 business days
 ABS body
 Automatic on/off
 Tube extends up to 120 cm
 Stop after 15 minutes of continuous operations

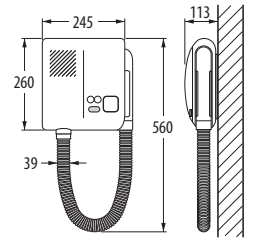

PickUp SL

03403 White

2 speeds
 Power: 230V
 Package weight: Kg. 2.200
 Availability: 2/3 business days
 ABS body
 Automatic on/off
 Tube extends up to 120 cm
 Stop on tube fall

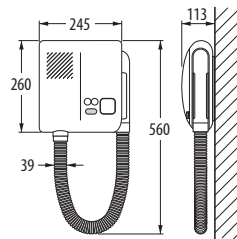

PickUp EL

03503 White

2 speeds
 Power: 230V
 Package weight: Kg. 2.200
 Availability: 2/3 business days
 ABS body
 Automatic on/off
 Tube extends up to 120 cm
 Stop after 15 minutes of continuous operations
 Stop on tube fall

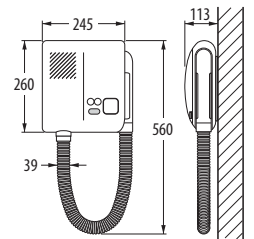

PickUp XLP

03603 White

2 speeds
 Power: 230V
 Package weight: Kg. 2.800
 Availability: 2/3 business days
 ABS body
 Automatic on/off
 Tube extends up to 120 cm
 Stop after 15 minutes of continuous operations
 Stop on tube fall
 Electric razor sockets (230V-120V)
 with safety transformer (max 10W)

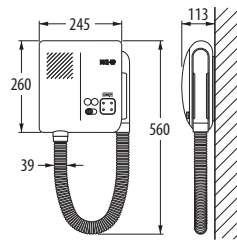

Jolly G

14203 White

1 speed
 Power: 230V
 Package weight: Kg. 2.150
 Availability: 2/3 business days
 ABS body
 Tube extends up to 120 cm
 Automatic on/off

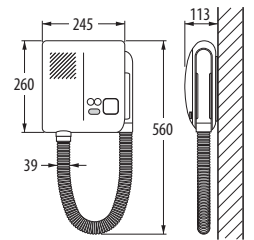

Nilo PK-53 Token timer for hairdryers

06953 DMP Token
06953.02 20 €/cent
06953.05 50 €/cent
06953.10 1 €

Power: 14 Vac transformer
 Package weight: Kg. 3.650
 Availability: 6 business days
 Rust-proof case
 12V relay (external) included to activate the hairdryer at 230V

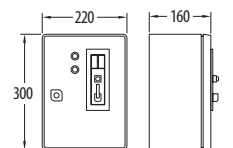

Certifications: **CE EMC** (models: PickUp EL, PickUp XLP, PickUp TL, Jolly G)
CE EMC  (models: PickUp L, PickUp SL)

Overview:

Saving water is a must in all hospitality establishments such as sports centres. The solution is at your fingertips, guaranteed by a simple and functional pair of electronic showers. Splash and Spin photocell activation will make facility managers happy with significantly lower water bills. Users will appreciate the advanced functions and convenient use. The plate is made of stainless steel with polished chrome finish.

Versions Available:

With built-in mixer
For cold or pre-mixed water

Power Available:

3 AA 1.5 V alkaline batteries.
230 Vac – 5 Vdc safety transformer.

Pluses:

Photocell activation
Guaranteed water savings
Hygiene and wellbeing
Easy to use
Long battery life
Manual operating mode
100% Made in Italy

Recommended for:

Sport



Hospitality



Public



Holiday



Spin



Splash

Features:

- DMP Infrared System photocell sensors, scratch proof and protected against calcium deposits
- Fully waterproof resined electronic circuit
- Water runs for 4/5 seconds after the person showering moves away (comfort in use)
- External glossy stainless steel plate or white and stainless steel recessed box (**FIG. 1**)
- DMP software programmed microchip for perfect function control
- Optimized functions for a long life of the alkaline batteries
- Autonomy of the batteries: 4-year battery life with 200 activations per day
- Low battery warning: a led in the sensors blinking twice every six seconds indicates that the batteries still have approx. 3 months autonomy
- Batteries easy to change and readily available (**FIG. 2**)
- Fully waterproof battery case
- Function for flood and consumption protection: the DMP shut-off timer stops the water flow after 5 minutes of continuous use
- Solenoid valve with triple, stainless steel and anti-impurities filter
- Shut-off valves inside the recessed box, equipped with stainless steel, anti-impurities 0.2 mm mesh filters

- Manual operation device (Splash-in 300 and Splash-mix 300 models)
- Concealed vandal-proof screws for plate mount (**FIG. 3**)

Technical Specifications:

- AA 1.5 V alkaline batteries
- Electronic circuit: 4.5 V, manufactured in compliance with CEI EN 55014-1/-2 requirements
- Solenoid valve: 3 V
- Safety transformer: 230Vac - 5Vdc, IMQ approved and manufactured in compliance with CEI EN 61558-1/-2-6 requirements
- IP65 electrical part protection grade
- Adjustable sensors' range of action: 10 - 60 cm
- Stop taps with non-return valves
- Water pressure: 0.4 - 10 bar
- Pipe fittings: 1/2 G

Package Contents:

- Electronic system for single shower Splash or Spin
- Stainless steel recessed cistern
- Installation kit
- Instruction manual
- Battery case with 3 alkaline batteries
or
- DMP safety transformer



FIG. 1

All Splash series models are equipped with stainless steel external plate and internal box. Safety and durability guaranteed.

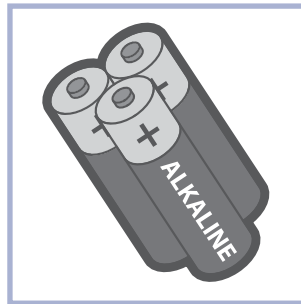

FIG. 2

Splash and Spin use standard AA size alkaline batteries, readily available in hypermarkets and corner shops. Easy to find, long-lasting.

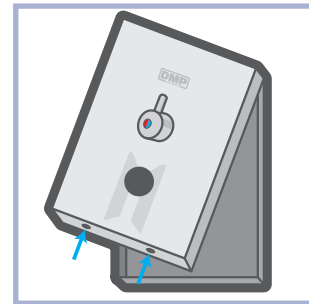

FIG. 3

The Splash and Spin fastening system is made up of a stainless steel frame and two concealed vandal-proof screws that guarantee plate hold.

Splashmix 200 BT



70406 Chrome
70403 White

With built-in mixer
Power: 3x1.5V AA alkaline batteries
Package weight: Kg. 3.350
Availability: 5 business days
Shower head not included

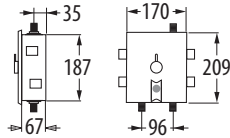

Splashmix 200



10406 Chrome
10403 White

With built-in mixer
Power: 5 Vdc transformer
Package weight: Kg. 3.450
Availability: 5 business days
Shower head not included

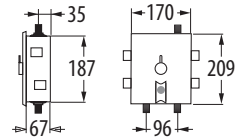

Splashmix 300 BT



70506 Chrome
70503 White

With built-in mixer
Power: 3x1.5V AA alkaline batteries
Package weight: Kg. 3.500
Availability: 5 business days
With manual mode function
Shower head not included

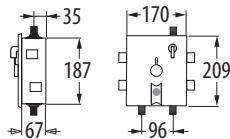

Splashmix 300



10506 Chrome
10503 White

With built-in mixer
Power: 5 Vdc transformer
Package weight: Kg. 3.600
Availability: 5 business days
With manual mode function
Shower head not included

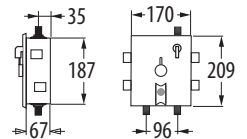

Spin 200 BT



84706 Chrome

For cold or pre-mixed water
Power: 3x1.5V AA alkaline batteries
Package weight: Kg. 1.300
Availability: 5 business days
Shower head not included

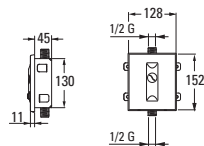

Spin 200



24706 Chrome

For cold or pre-mixed water
Power: 5 Vdc transformer
Package weight: Kg. 1.400
Availability: 5 business days
Shower head not included

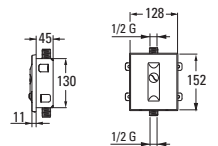

Transformers, batteries, flexible hoses, stop taps and accessories are all included in the price.

Certifications: **CE EMC ACS HACCP D.M.174 PCE** Safety Transformer **Y** (230Vac/5Vdc)

The recessed boxes can be supplied in advance, on demand.

Overview:

Reduce waste and rationalise water consumption. Nilo and Sc345 meet these needs, especially required by sport centres, seaside resorts and hospitality facilities in general. NILO is a single shower token control, equipped with an electronic unit that lets the operator regulate water flow to a variable 1 - 7 minute period. SC345 is able to control 2 to 5 showers simultaneously, each with a button that lets the user stop and start water flow as needed. Both models come with a shockproof and rustproof chassis.

Models Available:

Nilo, single shower control.

Sc345, multiple shower control.

Power Available:

230Vac – 14 Vac safety transformer (Nilo).

230Vac – 11 Vac safety transformer (Sc345).

Pluses:

Guaranteed water savings.

Hygiene and wellbeing.

Easy to use.

100% Made in Italy.

Recommended for:

Holiday



Sport



Hospitality



Nilo



Sc 345

Nilo Features:

- Single timed shower control, activated by DMP tokens (token machine available on request for 0.20€ - 0.50€ - 1€ coins)
- Time adjustable from 1 to 7 minutes (FIG. 1)
- Electronic circuit protected from humidity
- DMP software programmed microchip for perfect function control
- Rustproof and shockproof fiber glass case, made with special vandal-proof criteria
- A series of three water jets warn the user that 50 seconds are left to finish showering
- Vacant/occupied indicator lights
- Token dispenser block when shower is occupied
- Removable token tray
- Solenoid valve on **Standard model** (visible) or **Plus model** with protection covering and built-in anti-calcium shower head on request
- **Push function:** with button that stops/starts water flow (Nilo 922) (FIG. 2)
- **Smart function:** with button that stops/starts both water flow and timer, keeping effective available time (Nilo 942) (FIG. 3)
- Electronic circuit: 12 V
- Solenoid valve: 12 V
- Water pressure: 0.4 - 10 bar
- Pipe fittings: 1/2 G

Package Contents:

- Control for timed Nilo shower with solenoid valve
- Installation kit; instruction manual
- DMP safety transformer (230Vac/14Vac)

Sc345 Features:

- Multiple timed shower control, activated by DMP tokens (token machine available on request for 0.20€ - 0.50€ - 1€ coins)
- 2 – 5 shower cubicle control possibilities
- Sequential device to use shower boxes on rotation
- Time adjustable from 1 to 7 minutes (FIG. 1)
- Electronic circuit protected from humidity
- DMP software programmed microchip for perfect function control
- Rustproof and shockproof fiber glass case, made with special vandal-proof criteria
- A series of three water jets warn the user that 50 seconds are left to finish showering
- Vacant/occupied indicator lights
- Token dispenser block when shower is occupied
- Removable token tray
- Solenoid valve on **Standard model** (visible) or **Standard model** with protection covering and built-in anti-calcium shower head on request
- **Push function:** with button that stops/starts water flow. **Push function:** with button that stops/starts both water flow and timer, keeping effective time available (FIG. 3)
- Electronic circuit: 12 V
- Solenoid valve: 12 V
- Water pressure: 0.4 - 10 bar
- Pipe fittings: 1/2 G

Package Contents:

- Control for timed Sc345 shower with solenoid valves, buttons and plates for cubicle identification
- Installation kit; instruction manual
- DMP safety transformer (230Vac/11Vac)

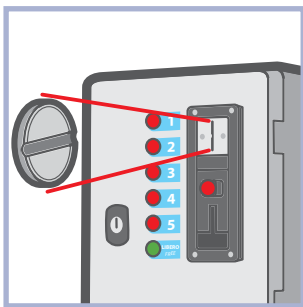

FIG. 1
Inserting a DMP token starts water flow for a period between 1 and 7 minutes, adjustable by the operator.

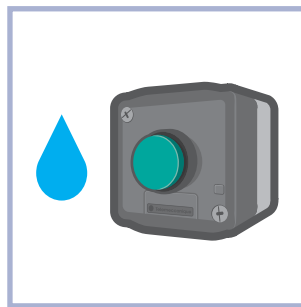

FIG. 2
Push function: the button stops and restarts water flow while assigned time continues to elapse.

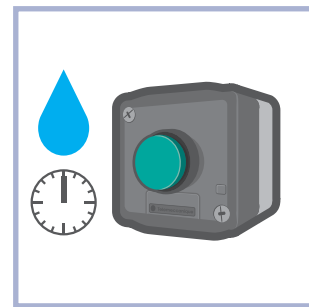

FIG. 3
Smart function: this function stops and restarts both water flow and the timer, letting the user exploit actual shower time.

Nilo 912



06912	DMP Token
06912.02	20 €/cent
06912.05	50 €/cent
06912.10	1 €

Power: 14 Vac transformer
Package weight: Kg.5.500

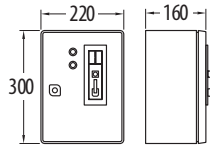

Nilo 922



06922	DMP Token
06922.02	20 €/cent
06922.05	50 €/cent
06922.10	1 €

Power: 14 Vac transformer
Package weight: Kg.5.600
ON/OFF button for water

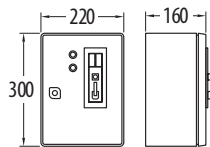

Nilo 942



06942	DMP Token
06942.02	20 €/cent
06942.05	50 €/cent
06942.10	1 €

Power: 14 Vac transformer
Package weight: Kg.5.600
ON/OFF button for water and time

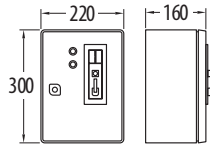

Nilo BT



66912	DMP Token
66912.02	20 €/cent
66912.05	50 €/cent
66912.10	1 €

Power: 3x1.5V AA alkaline batteries
Without token dispenser block
Package weight: Kg.4.800

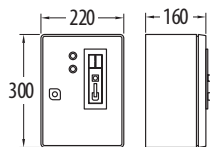

Common Features to Nilo

Availability: 6 business days
Solenoid valve mod. STANDARD included
Shower head not included

Solenoid valve Standard

Models on this page are supplied with:

- Standard solenoid valve group with stop tap and filter



Nilo Plus - Sc345 Plus

Each model on this page is also available in the PLUS version and supplied with:

- Solenoid valve group stop tap and filter
- Rust-proof shower arm and shower head with joint
- Adjustable stainless steel cover



For details on codes and features, refer to DMP Electronics Price List

Transformers and batteries are included in the price.

Certifications: **CE EMC D.M.174 PCE**

Nilo: Safety Transformer (230Vac/14Vac); **Sc345:** Safety Transformer (230Vac/11Vac)

Sc345 2 box doccia



07602	DMP Token
07602.02	20 €/cent
07602.05	50 €/cent
07602.10	1 €

Package weight: Kg. 6.900
2 STANDARD model solenoid valves included

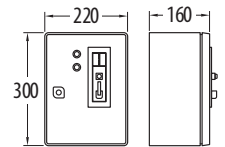

Sc345 3 box doccia



07603	DMP Token
07603.02	20 €/cent
07603.05	50 €/cent
07603.10	1 €

Package weight: Kg. 7.100
3 STANDARD model solenoid valves included

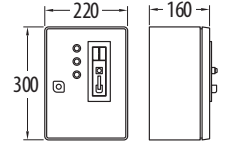

Sc345 4 box doccia



07604	DMP Token
07604.02	20 €/cent
07604.05	50 €/cent
07604.10	1 €

Package weight: Kg. 7.300
4 STANDARD model solenoid valves included

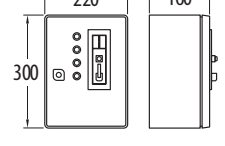

Sc345 5 box doccia



07605	DMP Token	
07605.02	20 €/cent	
07605.05	50 €/cent	
07605.10	1 €	€ 1.350,00

Package weight: Kg. 7.500
5 STANDARD model solenoid valves included

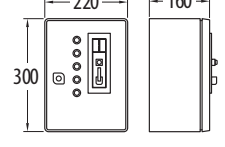

Common Features to Sc345

Power: transformer 11 Vac
Availability: 10 business days
ON/OFF button for water and/or time
Shower heads not included

Overview:

Available in a wide range of sizes and versions, Dce 28 is the most complete automatic shower control solution. In fact, the shower can be operated by a token, coin, magnetic card, key or magnetic bracelet according to the model. The electronic unit is able to simultaneously control from 2 to 8 showers, all equipped with a button that lets the user start and stop water flow at any time. Additionally, showers are not randomly assigned giving the user the chance to directly choose a shower.

Models Available:

Dce 28, token or coin operated.

Dce 28 Tag, magnetic card, key or bracelet operated.

Power Available:

230 Vac – 11 Vac safety transformer

Pluses:

Guaranteed water savings.

Hygiene and wellbeing.

Easy to use.

Wide range of sizes and versions.

100% Made in Italy.

Recommended for:

Holiday



Sport



Hospitality



Dce 28



Dce 28 Tag

Dce 28 Features:

- Multiple timed shower control, activated by DMP tokens (token machine available on request for 0.20€ - 0.50€ - 1€ coins)
- Models: from 2 to 8 shower boxes
- Light button in stainless steel for shower box selection
- Time adjustable from 1 to 7 minutes
- Water flow time doubled inserting 2 tokens or coins together (**FIG. 1**)
- Electronic circuit protected from humidity
- DMP software programmed microchip for perfect function control
- Rustproof and shockproof fiber glass case, made with special vandal-proof criteria
- A series of three water jets warn the user that 50 seconds are left to finish showering
- Vacant/occupied indicator lights
- Token dispenser block when shower is occupied
- Removable token tray
- Solenoid valve on **Standard model** (visible) or **Plus model** with protection covering and built-in anti-calcium shower head on request
- **Push function:** with button that stops/starts water flow. **Smart function:** with button that stops/starts both water flow and timer, keeping effective time available
- Electronic circuit: 12 V
- Solenoid valve: 12 V
- Water pressure: 0.4 - 10 bar
- Pipe fittings: 1/2 G

Package Contents:

- Control for timed Dce 28 shower with solenoid valves, buttons and plates for cubicle identification
- Installation kit; instruction manual
- DMP safety transformer (230Vac/11Vac)

Dce 28 Tag Features:

- Multiple timed shower control, activated by rechargeable magnetic cards, keys or bracelets (**FIG. 2 and 3**)
- Alphanumeric display to view credit
- Models: from 2 to 8 shower boxes
- Light button in stainless steel for shower box selection
- Time adjustable from 1 to 7 minutes
- Water flow doubled (with two approaches of the TAG key or of the magnetic card on the sensor)
- Electronic circuit protected from humidity
- DMP software programmed microchip for perfect function control
- Rustproof and shockproof fiber glass case, made with special vandal-proof criteria
- A series of three water jets warn the user that 50 seconds are left to finish showering
- Vacant/occupied indicator lights
- Solenoid valve on **Standard model** (visible) or **Plus model** with protection covering and built-in anti-calcium shower head on request
- **Push function:** with button that stops/starts water flow. **Smart function:** with button that stops/starts both water flow and timer, keeping effective time available
- Electronic circuit: 12 V
- Solenoid valve: 12 V
- Water pressure: 0.4 - 10 bar
- Pipe fittings: 1/2 G

Package Contents:

- Control for timed Dce 28 Tag shower with solenoid valves, buttons and plates for cubicle identification
- Installation kit; instruction manual
- DMP safety transformer (230Vac/11Vac)

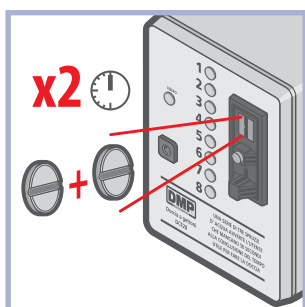

FIG. 1
Water flow time can be doubled with Dce 28 by simply inserting two tokens before starting the shower.

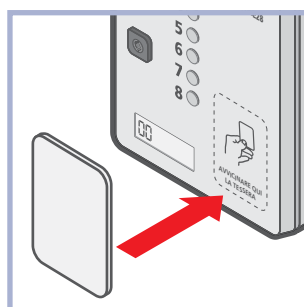

FIG. 2
Dce 28 Tag comes with three operating modes. One of these includes the use of an approach magnetic card.

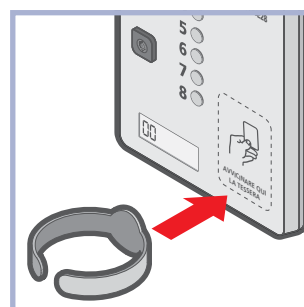

FIG. 3
As an alternative to the magnetic card, Dce 28 Tag can be operated with a bracelet (illustrated) or key, both in approach.



Dce 28 ST from 2 to 8 shower boxes



Operation: DMP Token
Operation: 20 €/cent
Operation: 50 €/cent
Operation: 1 €

Power: 11 Vac transformer
 Package weight: Kg. 7.400 ÷ 8.600
 Availability: 6 business days
 ON/OFF button for water
 Works with tokens or coins
 Possibility to choose box
 Shower head not included
From 2 to 8 solenoids included

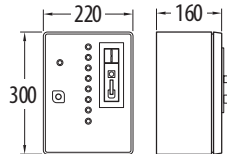

Dce 28 Tag ST from 2 to 8 shower boxes



Operation: Card, key or bracelet

Power: 11 Vac transformer
 Package weight: Kg. 7.100 ÷ 8.300
 Availability: 10 business days
 ON/OFF button for water
 Alphanumeric display
 Works with magnetic card, key or bracelet
 Possibility to choose box
 Shower head not included
From 2 to 8 solenoids included

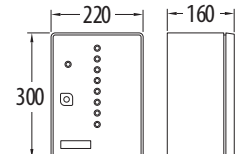

Ric-Tag-010



Programmable credit charger

With built-in power supply
 With software installation CD
 USB port for connection to a PC

Solenoid valve Standard

Models on this page are supplied with:

- Standard solenoid valve group with stop tap and filter



Dce 28 Plus - Dce 28 Tag Plus

Each model on this page is also available in the PLUS version and supplied with:

- Solenoid valve group stop tap and filter
- Rust-proof shower arm and shower head with joint
- Adjustable stainless steel cover



For details on codes and features, refer to DMP Electronics Price List.

Transformers and batteries are included in the price.

Certifications: **CE EMC D.M.174**  Safety Transformer (230Vac/11Vac)

Overview:

When Fin was conceived, DMP designers thought of everything: scalability, energy savings and the essentials of public hygiene. The result of their efforts is a hi-tech and highly reliable electronic control unit. The product is available in two types: one flushes on approach meaning water flows when someone nears the sensors' range; the second flushes when leaving meaning water flows when someone moves out of the range.

Versions Available:

Flush on approach.

Flush on leaving.

Power Available:

2 AA 1.5 V alkaline batteries.

230 Vac – 5 Vdc safety transformer.

Pluses:

Photocell activation.

Hygiene and wellbeing.

Long battery life.

Guaranteed water savings.

Manual mode operations.

100% Made in Italy.

Recommended for:

Public



Hospitality



Catering



Industry



Features:

- Recessed electronic system for single urinal equipped with DMP Infrared System photocell sensors, scratch proof and protected against calcium deposits
- Fully waterproof resined electronic circuit
- External glossy stainless steel plate and 45 mm deep internal chassis (**FIG. 1**)
- DMP software programmed microchip for perfect function control
- Optimized functions for a long life of the alkaline batteries
- Autonomy of the batteries: 4-year battery life with 200 activations per day
- Low battery warning: a led in the sensors blinking twice every six seconds indicates that the batteries still have approx. 3 months autonomy
- Batteries easy to change and readily available
- Fully waterproof battery case
- Flush on approach or leaving (**FIG. 2 and 3**)
- Automatic flush every 12 hours
- Manual operation device (Fin 300)
- Solenoid valve with triple, stainless steel and anti-impurities filter

- Shut-off valves inside the recessed box, equipped with stainless steel, anti-impurities 0.2 mm mesh filters and water flow regulator
- Concealed vandal-proof screws for plate mount

Technical Specifications:

- AA 1.5 V alkaline batteries
- Electronic circuit: 3 V, manufactured in compliance with CEI EN 55014-1/-2 requirements
- Solenoid valve: 2 V
- IP65 electrical part protection grade
- Sensors' range of action: 20 - 80 cm
- Water pressure: 0.4 - 10 bar
- Pipe fittings: 1/2 G

Package Contents:

- Recessed electronic system for single urinal Fin
- Recessed stainless steel box
- Vandal-proof key for plate fastening
- Installation kit
- Instruction manual
- Battery case with 2 alkaline batteries
or
- DMP safety transformer

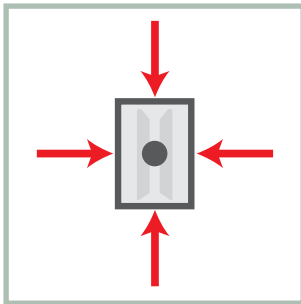

FIG. 1

The Fin external plate and internal chassis are the results of design intended to reduce space and provide maximum installation ease.

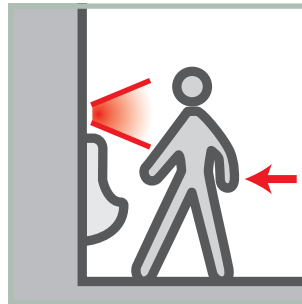

FIG. 2

Models equipped with this function flush water when someone approaches the sensors and stops flow 10 seconds after leaving.

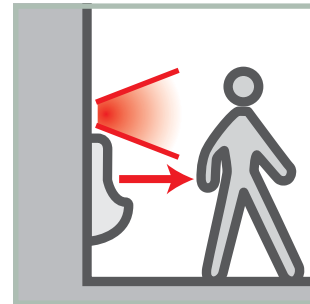

FIG. 3

In models with this function, water flushes as soon as the user leaves the sensor range and lasts for a period of time set by the operator (from 4 to 16 seconds).

Fin 200 BT



82806 Chrome
Approach

82826 Chrome
Leaving

Power: 2x1.5V AA alkaline batteries
Package weight: Kg. 1.350
Availability: 2/3 business days
Stainless steel external plate
and internal box

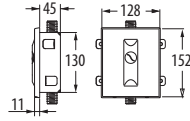

Fin 200



22806 Chrome
Approach

22826 Chrome
Leaving

Power: 5 Vdc transformer
Package weight: Kg. 1.500
Availability: 2/3 business days
Stainless steel external plate
and internal box

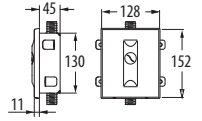

Fin 300 BT



84606 Chrome
Approach

84606 Chrome
Leaving

Power: 2x1.5V AA alkaline batteries
Package weight: Kg. 1.400
Availability: 2/3 business days
Stainless steel external plate
and internal box
With manual mode function

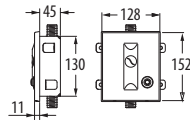

Fin 300



24606 Chrome
Approach

24626 Chrome
Leaving

Power: 5 Vdc transformer
Package weight: Kg. 1.550
Availability: 2/3 business days
Stainless steel external plate
and internal box
With manual mode function

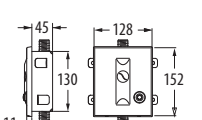

Transformer, batteries and accessories are all included in the price.

Certifications: **CE EMC D.M.174** Safety Transformer (230Vac/5Vdc)

The recessed boxes can be supplied in advance, on demand.

Overview:

Renovate public washroom systems according to hygiene and energy saving criteria without costly renovations. All this is possible with Flush Comp, an external electronic control for urinals, extremely compact and made of chrome-plated brass. The product is available with approach and leaving flush and a removable filter with built-in DMP stop tap to regulate water quantity. Furthermore, it comes in four different models, to adjust to any type of plumbing system.

Versions Available:

Flush on approach.

Flush on leaving.

Power Available:

2 AA 1.5 V alkaline batteries.

Pluses:

Photocell activation.

Hygiene and wellbeing.

Long battery life.

Guaranteed water savings.

100% Made in Italy.

Recommended for:

Public



Hospitality



Catering



Features:

- DMP photocell sensors, made of scratchproof and calcium resistant material
- Fully waterproof resined electronic circuit
- Chrome-plated brass body and hood, made with special vandal-proof criteria
- DMP software programmed microchip for perfect function control
- Optimized functions for a long life of the alkaline batteries
- Autonomy of the batteries: 4-year battery life with 200 activations per day
- Low battery warning: a led in the sensors blinking twice every six seconds indicates that the batteries still have approx. 3 months autonomy
- Batteries easy to change and readily available
- Flush on approach or leaving (**FIG. 1 and 2**)
- Automatic flush every 12 hours
- Top plumbing connection possibilities (Flush-comp BT NV)
- Solenoid valve with triple, stainless steel and anti-impurities filter
- Shut-off valves inside the recessed box, equipped with stainless steel, anti-impurities 0.2 mm mesh filters and water flow regulator (**FIG. 3**)
- Concealed vandal-proof screws for chassis and hood mount

Technical Specifications:

- AA 1.5 V alkaline batteries
- Electronic circuit: 3 V, manufactured in compliance with CEI EN 55014-1/-2 requirements
- Solenoid valve: 3 V
- IP65 electrical part protection grade
- Sensors' range of action: 20 - 80 cm
- Water pressure: 0.4 - 10 bar
- Pipe fittings: 1/2 G (Flush Comp 1 BT, Flush Comp 1 BT NV 12)
- Pipe fittings: 3/4 G (Flush Comp 1 BT NV 34)
- Pipe fittings: 1 G (Flush Comp 1 BT NV 10)

Package Contents:

- All-in-One electronic control for single ceramic urinal Flush Comp BT
- Vandal-proof key for plate fastening
- Instruction manual
- Battery case with 2 alkaline batteries

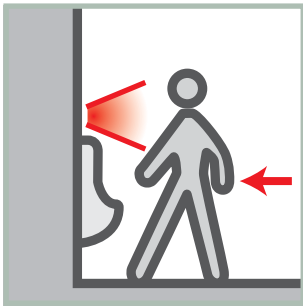

FIG. 1

Models equipped with this function flush water when someone approaches the sensors and stops flow 10 seconds after leaving.

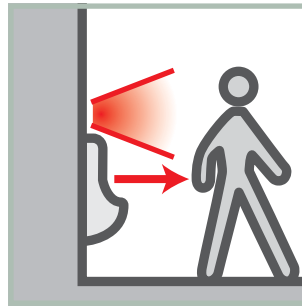

FIG. 2

In models with this function, water flushes as soon as the user leaves the sensor range and lasts for a period of time set by the operator (from 4 to 16 seconds).

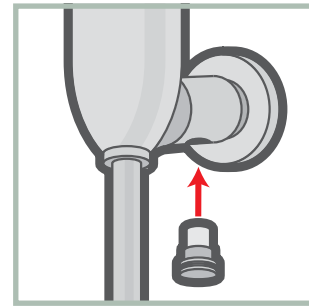

FIG. 3

Flush Comp comes with a stop tap with stainless steel mesh filter that can be removed for inspection and internal part cleaning.

Flush Comp 1 BT



78806 Chrome
Approach

78826 Chrome
Leaving

Power: 2x1.5V AA alkaline batteries
Package weight: Kg. 1.300
Availability: 2/3 business days
Wall cistern plumbing 1/2 G

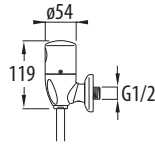

Flush Comp 1 BT NV 12



79006 Chrome
Approach

79026 Chrome
Leaving

Power: 2x1.5V AA alkaline batteries
Package weight: Kg. 1.650
Availability: 2/3 business days
High cistern plumbing

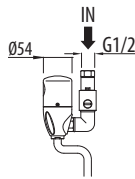

Flush Comp 1 BT NV 34



79406 Chrome
Approach

79426 Chrome
Leaving

Power: 2x1.5V AA alkaline batteries
Package weight: Kg. 1.670
Availability: 2/3 business days
High cistern plumbing

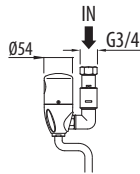

Flush Comp 1 BT NV 10



77806 Chrome
Approach

77826 Chrome
Leaving

Power: 2x1.5V AA alkaline batteries
Package weight: Kg. 1.700
Availability: 2/3 business days
High cistern plumbing

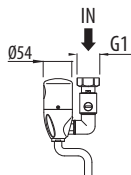

Transformer, batteries and accessories are all included in the price.

Certifications: **EMC ACS HACCP D.M.174**

Overview:

This ceramic urinal pod maintains the traditional functional design but has a built-in electronic control that automatically controls flushing. Saniflush has been designed as an all-in-one system, easy to install and maintain. Two versions are available, with flush on approach or on leaving. Stainless steel floor washing grid also available.

Versions Available:

Flush on approach.

Flush on leaving.

Intermittent flushing.

Power Available:

3 AA 1.5 V alkaline batteries.

230 Vac + 5 Vdc safety transformer.

Pluses:

Photocell activation.

Hygiene and wellbeing.

Long battery life.

Easy to install.

Easy maintenance.

Guaranteed water savings.

100% Made in Italy.

Recommended for:

Public



Hospitality



Catering



Industry



Features:

- DMP photocell sensors, made of 4 mm scratchproof glass protected against calcium deposits
- Fully waterproof resined electronic circuit
- Sensors' body in AISI 316 marine stainless steel (maximum resistance against acids)
- DMP software programmed microchip for perfect function control
- Optimized functions for a long life of the alkaline batteries
- Autonomy of the batteries: 4-year battery life with 200 activations per day
- Low battery warning: a led in the sensors blinking twice every six seconds indicates that the batteries still have approx. 3 months autonomy
- Batteries easy to change and readily available
- Fully waterproof battery case
- Intermittent water flush or flush on a person's approach and leaving
- Automatic flush every 12 hours
- Floor washing grid settings with 2nd solenoid valve on request (Saniflush Lpv) (**FIG. 1**)
- Solenoid valve with triple, stainless steel and anti-impurities filter
- Stop tap with stainless steel, anti-impurities 0.2 mm mesh filter and water flow regulator

- Stainless steel universal wall bracket (**FIG. 2 and 3**)
- Built in Ø 40 mm jointed tube (**FIG. 3**)
- Drain holes to prevent the entrance of cigarettes

Technical Specifications:

- AA 1.5 V alkaline batteries
- Electronic circuit: 4.5 V, manufactured in compliance with CEI EN 55014-1/-2 requirements
- Solenoid valve: 3 V
- IP65 electrical part protection grade
- Sensors' range of action: 20 - 80 cm
- Water pressure: 0.4 - 10 bar
- Pipe fittings: 1/2 G
- Ceramic urinal pod; colour: white

Package Contents:

- All-in-one electronic system for single ceramic urinal Saniflush
- Installation kit
- Instruction manual
- Battery case with 3 alkaline batteries
or
- DMP safety transformer

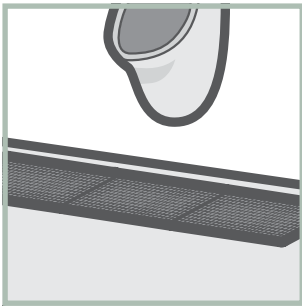

FIG. 1

The Saniflush LPV versions have a second solenoid valve that drains on the floor washing grids, available upon request

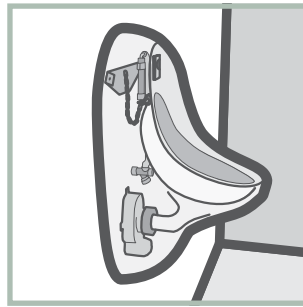

FIG. 2

Saniflush is the only all-in-one electronic urinal able to guarantee easy and 100% safe installation, thanks to the supplied stainless steel bracket.

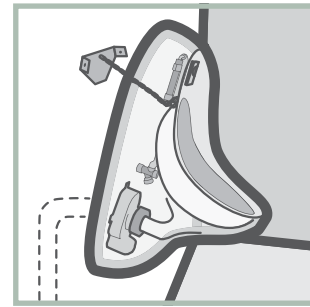

FIG. 3

The urinal pod is secured to the bracket with two screws. Totally safe internal inspection by the installation technician.

Saniflush Mtd BT



74316 Approach

74456 Leaving

Power: 3x1.5V AA alkaline batteries
 Package weight: Kg. 24.900
 Availability: 2/3 business days
 Ceramic pod; colour: white
 Sensor body in marine grade 316 stainless steel

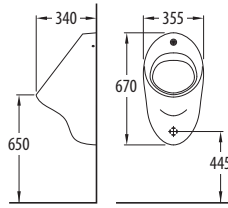

Saniflush Mtd



14316 Approach

14456 Leaving

Power: 5 Vdc transformer
 Package weight: Kg. 25.000
 Availability: 2/3 business days
 Ceramic pod; colour: white
 Sensor body in marine grade 316 stainless steel

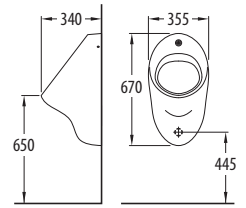

Saniflush Lpv Mtd BT



74336 Approach

74476 Leaving

Power: 3x1.5V AA alkaline batteries
 Package weight: Kg. 24.900
 Availability: 2/3 business days
 Sensor body in marine grade 316 stainless steel
 Ceramic pod; colour: white
 With 2 solenoid valves and floor washing settings

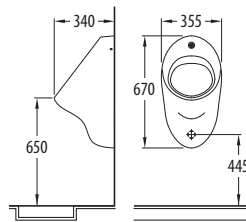

Saniflush Lpv Mtd



14336 Approach

14486 Leaving

Power: 5 Vdc transformer
 Package weight: Kg. 25.500
 Availability: 2/3 business days
 Sensor body in marine grade 316 stainless steel
 Ceramic pod; colour: white
 With 2 solenoid valves and floor washing settings

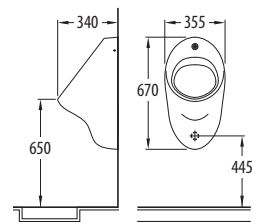

Saniflush Ra Mtd



14396 Approach

Power: 5 Vdc transformer
 Package weight: Kg. 25.000
 Availability: 2/3 business days
 Sensor body in marine grade 316 stainless steel
 Ceramic pod; colour: white

Intermittent operation:
a 4-second flush every 6 seconds

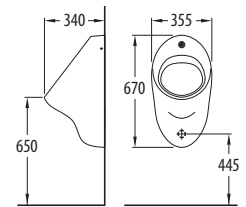

Transformer, batteries and accessories are all included in the price.

Certifications: **CE EMC D.M.174** Safety Transformer (230Vac/5Vdc)

Overview:

The River Extra system activates when the user interrupts the sensor's optical barrier. Water flushes for the entire time the sensor detects the user. When the user moves away, water continues to flush for an extra period of time (adjustable from 1 to 10 seconds).

Power:

- IMQ approved 230 Vac – 14Vac safety transformer constructed according to CEI EN 61558-1/-2-6 standards.

Features:

- DMP photocell sensors, made of scratchproof and calcium resistant material
- Fully waterproof resined electronic circuit to be installed opposite sensors
- Stainless steel external plate with vandal-proof screws
- DMP software programmed microchip for perfect function control
- Flush activated by user presence
- After leaving, water flushes for an adjustable period of time between 1 and 10 seconds
- 70 cm deep recessed cistern

- Stop tap equipped with stainless steel mesh filter
- Vandal-proof plate fastening screws

Technical Specifications:

- Electronic circuit: 12 V, manufactured in compliance with CEI EN 55014-1/-2 requirements
- Solenoid valve: 12 V
- IP65 electrical part protection grade
- Sensor range of action: max 10 metres with reflector
- Water pressure: 0.4 - 7 bar
- Plumbing features: ½ G or ¾ G

Package Contents:

- Barrier electronic system for River Extra urinal series
- Vandal-proof key for plate fastening
- Instruction manual
- DMP safety transformer

River Extra 200



07716	Chrome ½" solenoid valve	Package weight: Kg.1.600
07736	Chrome ¾" solenoid valve	Package weight: Kg.2.100

Power: 14 Vac transformer
Availability: 2/3 business days
Electronic barrier control for urinals
Range of action up to 10 metres



Recommended for:



Public



Industry

Overview:

Dikaflush is a DMP project specifically designed to contain both the electronic control and recessed cistern in a single product, both found in the package. It adapts to all types of WCs, both standard and hanging; in the latter case, a specific techno-structure (Dikaflush tecno) is provided. Available with flush on leaving or, in alternative, especially for small restrooms, a special sensor that activates flushing on hand approach.

Versions Available:

Flush on leaving.

Flush on hand approach.

Power Available:

3 AA 1.5 V alkaline batteries.

230Vac - 5Vdc safety transformer.

Pluses:

Photocell activation.

Hygiene and wellbeing.

Long battery life.

Suitable for both standard or hanging WCs.

Manual mode operations.

100% Made in Italy.

Recommended for:

Public



Catering



Hospitality



Health



Features:

- DMP photocell sensors, made of scratchproof and calcium resistant material
- Fully waterproof resined electronic circuit
- Stainless steel external plate with vandal-proof screws
- DMP software programmed microchip for perfect function control
- Optimized functions for a long life of the alkaline batteries
- Autonomy of the batteries: 4-year battery life with 200 activations per day
- Low battery warning: a led in the sensors blinking twice every six seconds indicates that the batteries still have approx. 3 months autonomy
- Batteries easy to change and readily available **(FIG. 1)**
- Fully waterproof battery case
- Flush according to installed circuit model:
ST models: without pre-flush
VL models: with pre-flush before main flush
- Manual operation device
- Metallic techno-structure for hanging WC (Dikaflush Tecno) **(FIG. 2)**
- Optional: Sensor with hand approach activation **(FIG. 3)**
- Automatic flush every 12 hours

- Solenoid valve with triple, stainless steel and anti-impurities filter
- Shut-off valves inside the recessed box, equipped with stainless steel, anti-impurities 0.2 mm mesh filters with water flow regulator

Technical Specifications:

- AA 1.5 V alkaline batteries
- Electronic circuit: 4.5 V, manufactured in compliance with CEI EN 55014-1/-2 requirements
- Solenoid valve: 3 V
- IP65 electrical part protection grade
- Sensors' range of action: 20 - 80 cm
- Water pressure: 0.4 - 10 bar
- Pipe fittings: 1/2 G
- Cistern capacity from 6 to 9 liters

Package Contents:

- Electronic control for WC with concealed cistern Dikaflush and drain connections
- Vandal-proof key for plate fastening
- Installation kit
- Instruction manual
- Battery case with 3 alkaline batteries
or
- DMP safety transformer



FIG. 1

Dikaflush uses standard AA size alkaline batteries, readily available in hypermarkets as well as in corner shops. Easy to find, long-lasting.



FIG. 2

Dikaflush Tecno is the ideal version for hanging WCs. The techno-structure is made of painted tubular metal. It can support up to 400 kg.

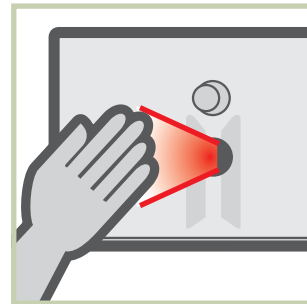

FIG. 3

Dikaflush and Dikaflush Tecno can also be installed in small restrooms thanks to the DMP hand approach sensor.

Dikaflush-St

74706 Dikaflush-St BT 3x1.5V AA alkaline batteries 

14706 Dikaflush-St 5 Vdc transformer 

Package weight: Kg. 5.100 ÷ 5.200
 Availability: 5 business days
 Cistern capacity from 6 to 9 liters
 Stainless steel external plate
 Without pre-flush
 With manual mode function

Dikaflush-St 34

74716 Dikaflush-St 34 BT 3x1.5V AA alkaline batteries 

14716 Dikaflush-St 34 5 Vdc transformer 

Package weight: Kg. 5.100 ÷ 5.200
 Availability: 5 business days
 Cistern capacity from 6 to 9 liters
 Stainless steel external plate
 Without pre-flush
 With manual mode function
Hand approach

Dikaflush-VL

74906 Dikaflush-VL BT 3x1.5V AA alkaline batteries 

14906 Dikaflush-VL 5 Vdc transformer 

Package weight: Kg. 5.900 ÷ 6.000
 Availability: 5 business days
 Cistern capacity from 6 to 9 liters
 Stainless steel external plate
 With pre-flush
 With manual mode function

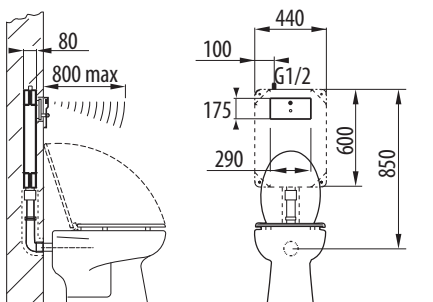

All Dikaflush products have the same measurements.

Dikaflush Tecno-St

75506 Dikaflush Tecno-St BT 3x1.5V AA alkaline batteries 

15506 Dikaflush Tecno-St 5 Vdc transformer 

Package weight: Kg. 19.100 ÷ 19.200
 Availability: 10 business days
 Cistern capacity from 6 to 9 liters
 Metal frame for hanging WC
 Stainless steel external plate
 Without pre-flush
 With manual mode function

Also suitable for mounting on plasterboard

Dikaflush Tecno-St 34

75516 Dikaflush Tecno-St 34 BT 3x1.5V AA alkaline batteries 

15516 Dikaflush Tecno-St 34 5 Vdc transformer 

Package weight: Kg. 19.100 ÷ 19.200
 Availability: 10 business days
 Cistern capacity from 6 to 9 liters
 Metal frame for hanging WC
 Stainless steel external plate
 Without pre-flush
 With manual mode function

Hand approach

Also suitable for mounting on plasterboard

Dikaflush Tecno-VL

75806 Dikaflush Tecno-VL BT 3x1.5V AA alkaline batteries 

15806 Dikaflush Tecno-VL 5 Vdc transformer 

Package weight: Kg. 19.900 ÷ 20.000
 Availability: 10 business days
 Cistern capacity from 6 to 9 liters
 Metal frame for hanging WC
 Stainless steel external plate
 With pre-flush
 With manual mode function

Also suitable for mounting on plasterboard

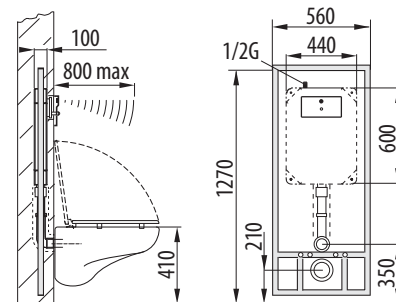

All Dikaflush Tecno products have the same measurements. Technostructures for baby pods are also available. For more details refer to DMP Electronics Price List.

Transformers, batteries and accessories are all included in the price.

Certifications:    D.M.174  Safety Transformer  (230Vac/5Vdc)

Overview:

Equipped with a stainless steel external plate and support frame, M-Lux and M-Fix are two electronic WC flush valves that differ by a single feature: M-Lux includes a hygienic plus to provide pre-flush during use before full flush. In addition to flush on leaving, models with hand approach sensors are available as an alternative, especially for small restrooms.

Versions Available:

Flush on leaving.

Flush on hand approach.

Power Available:

3 AA 1.5 V alkaline batteries.

230Vac - 5Vdc safety transformer.

Pluses:

Photocell activation.

Hygiene and wellbeing.

Long battery life.

Suitable for both standard or hanging WCs.

Manual mode operations.

100% Made in Italy.

Recommended for:

Public



Catering



Hospitality



Health



Industry

M-LUX / M-Fix



Features:

- DMP photocell sensors, made of scratchproof and calcium resistant material
- Fully waterproof resined electronic circuit
- Stainless steel internal box and external plate
- DMP software programmed microchip for perfect function control
- Optimized functions for a long life of the alkaline batteries
- Autonomy of the batteries: 4-year battery life with 200 activations per day
- Low battery warning: a led in the sensors blinking twice every six seconds indicates that the batteries still have approx. 3 months autonomy
- Batteries easy to change and readily available (**FIG. 1**)
- Fully waterproof battery case
- Automatic flush every 12 hours
- Internal anti-water hammer PISTON for water flush and self-cleaning filters (**FIG. 2**)
- Pre-flush on approach, quantity adjustable on internal screw (M-Lux)
- Salt water resistant brass valve body and parts
- Adjustable flush from 2 to 8 seconds
- Optional: Sensor with hand approach activation (**FIG. 3**)
- Concealed vandal-proof screws for plate mount

Technical Specifications:

- AA 1.5 V alkaline batteries
- Electronic circuit: 4.5 V, manufactured in compliance with CEI EN 55014-1/-2 requirements
- Solenoid valve: 3 V
- IP65 electrical part protection grade
- Sensors' range of action: 75 cm max
- Water pressure: 1 - 7 bar
- Pipe fittings: 3/4 G

Package Contents:

- Recessed electronic system for WC or urinal with internal flush valve complete with stainless steel built-in box
- Vandal-proof key for plate fastening
- Installation kit
- Instruction manual
- Battery case with 3 alkaline batteries
or
- DMP safety transformer

Attention - Important

The hydraulic system must have 3/4 G tubes (minimum) and 90/100 l/min. at 3 bars water input (minimum) for each single device. Should many products be used at the same time, increase the hydraulic system tubes so as to constantly guarantee 90/100 l/min. at 3 bars.



FIG. 1

M-Lux and M-Fix use standard AA size alkaline batteries, readily available in supermarkets as well as in corner shops. Easy to find, long-lasting.

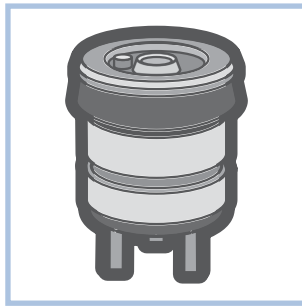

FIG. 2

One of a kind, M-Lux and M-Fix are equipped with a self-cleaning brass PISTON instead of a classic membrane to eliminate irritating flush water hammer.

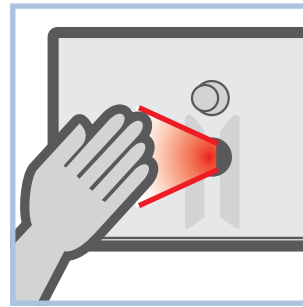

FIG. 3

M-Lux and M-Fix can also be installed in small restrooms thanks to the DMP hand approach sensor.

M-Lux 200 BT



83006 Chrome

Power: 3x1.5V AA alkaline batteries
 Package weight: Kg. 3.200
 Availability: 5 business days
 Plumbing 3/4 G min.
 With pre-flush
 Stainless steel external plate and internal box

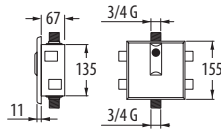

M-Lux 200



23006 Chrome

Power: 5 Vdc transformer
 Package weight: Kg. 3.300
 Availability: 5 business days
 Plumbing 3/4 G min.
 With pre-flush
 Stainless steel external plate and internal box

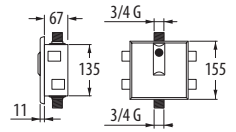

M-Lux 300 BT



84006 Chrome

Power: 3x1.5V AA alkaline batteries
 Package weight: Kg. 3.350
 Availability: 5 business days
 Plumbing 3/4 G min.
 With pre-flush
 Stainless steel external plate and internal box
 With manual mode function

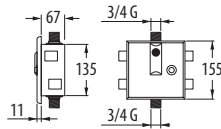

M-Lux 300



24006 Chrome

Power: 5 Vdc transformer
 Package weight: Kg. 3.450
 Availability: 5 business days
 Plumbing 3/4 G min.
 With pre-flush
 Stainless steel external plate and internal box
 With manual mode function

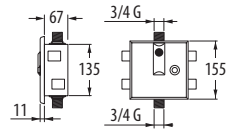

M-Fix 200 BT



80906 Chrome

Power: 3x1.5V AA alkaline batteries
 Package weight: Kg. 2.800
 Availability: 5 business days
 Plumbing 3/4 G min.
 Without pre-flush
 Stainless steel external plate and internal box

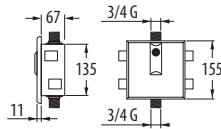

M-Fix 200



20906 Chrome

Power: 5 Vdc transformer
 Package weight: Kg. 2.900
 Availability: 5 business days
 Plumbing 3/4 G min.
 Without pre-flush
 Stainless steel external plate and internal box

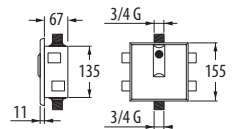

M-Fix 300 BT



81906 Chrome

Power: 3x1.5V AA alkaline batteries
 Package weight: Kg. 2.950
 Availability: 5 business days
 Plumbing 3/4 G min.
 Without pre-flush
 Stainless steel external plate and internal box
 With manual mode function

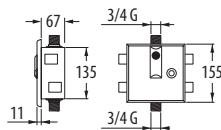

M-Fix 300



21906 Chrome

Power: 5 Vdc transformer
 Package weight: Kg. 3.050
 Availability: 5 business days
 Plumbing 3/4 G min.
 Without pre-flush
 Stainless steel external plate and internal box
 With manual mode function

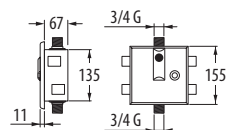

Transformers, batteries and accessories are all included in the price.

Certifications: EMC D.M.174 Safety Transformer (230Vac/5Vdc)

The recessed boxes can be supplied in advance, on demand.

Overview:

FM14300 is the electronic external flush valve for WCs and urinal flushing. Its main feature is its immediate adaptability to new and old systems: a manual flush valve system can be replaced with the FM14300 electronic system in just a few minutes. Fully made of cast brass and, one of a kind, it is equipped with a piston, also made of brass, that replaces the classic membrane. This detail eliminates irritating flush "water hammer". Flush is automatic one second after the user leaves.

Versions Available:

Flush on leaving.

Power Available:

2 AA 1.5 V alkaline batteries.

Pluses:

Photocell activation.

Hygiene and wellbeing.

Long battery life.

Suitable for both urinals and WCs.

Manual mode operations.

100% Made in Italy.

Recommended for:

Public



Catering



Hospitality



Health



Features:

- DMP photocell sensors, made of scratchproof and calcium resistant material
- Fully waterproof resined electronic circuit
- Chrome-plated brass body, constructed with specific vandal-proof criteria
- DMP software programmed microchip for perfect function control
- Optimized functions for a long life of the alkaline batteries
- Autonomy of the batteries: 4-year battery life with 200 activations per day
- Low battery warning: a led in the sensors blinking twice every six seconds indicates that the batteries still have approx. 3 months autonomy
- Batteries easy to change and readily available (**FIG. 1**)
- Fully waterproof battery case
- Flush on person's leaving
- Internal trimmer regulates water flow (from 2 to 8 seconds)
- Function for manual (**FIG. 2**)
- Self-cleaning and anti-water hammer PISTON opening and closing (**FIG. 3**)
- Automatic flush every 12 hours
- Installation possibility with right side water input (mod. DX) or left (mod. SX)
- Vandal-proof screws for hood mount

Technical Specifications:

- AA 1.5 V alkaline batteries
- Electronic circuit: 3 V, manufactured in compliance with CEI EN 55014-1/-2 requirements
- Solenoid valve: 2 V
- IP65 electrical part protection grade
- Sensors' range of action: max 80 cm
- Water pressure: 1.4 - 7 bar
- Pipe fittings: 1 G

Package Contents:

- Electronic flush valve for WC and urinal FM14300 (water input and output couplings not included in kit)
- Vandal-proof screwdriver for screw mount
- Instruction manual
- Battery case with 2 alkaline batteries

Attention - Important

The hydraulic system must have 3/4 G tubes (minimum) and 90/100 l/min. at 3 bars water input (minimum) for each single device. Should many products be used at the same time, increase the hydraulic system tubes so as to constantly guarantee 90/100 l/min. at 3 bars.

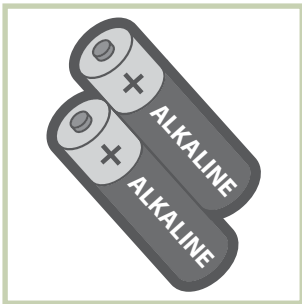

FIG. 1

FM 14300 uses standard AA size alkaline batteries, readily available in hypermarkets as well as in corner shops. Easy to find, long-lasting.

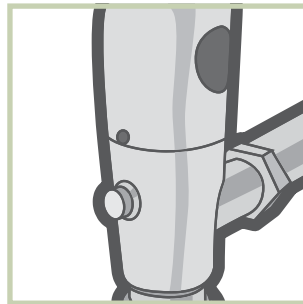

FIG. 2

If batteries deplete, the FM14300 button is a REAL manual button because it directly interacts on plumbing as a by-pass.

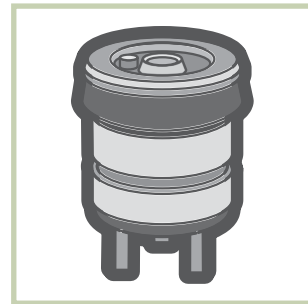

FIG. 3

One of a kind, FM 14300 is equipped with a self-cleaning brass PISTON instead of a classic membrane to eliminate irritating flush water hammer.

Fm 14300 BT Sln



84306 Chrome
Left side water inlet

84307 Chrome
Right side water inlet

Power: 2x1.5V AA alkaline batteries
Package weight: Kg. 2.100
Availability: 5 business days
With manual mode function

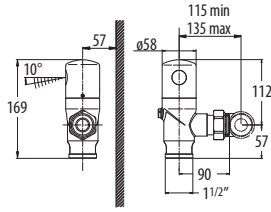

Fm 14300 BT Lt



84426 Chrome
Right side water inlet

Power: 2x1.5V AA alkaline batteries
Package weight: Kg. 2.100
Availability: 5 business days
With manual mode function

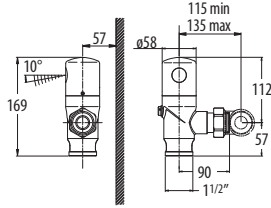

Fm 14300 BT Frt



84415 Chrome
Top water inlet

Power: 2x1.5V AA alkaline batteries
Package weight: Kg. 2.100
Availability: 5 business days
With manual mode function

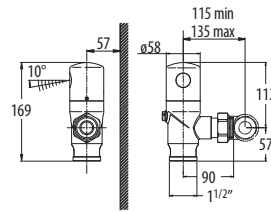

Pack-1 WC Kit

Pack-2 urinals Kit

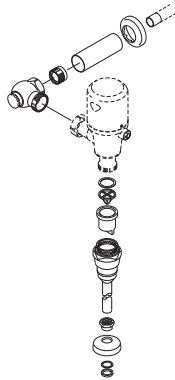
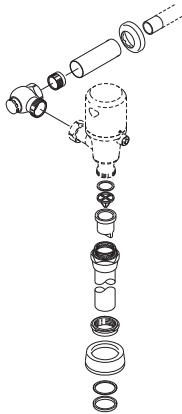

Plumbing Kit Available

Pack-1 WC

Code 65210
Package weight: Kg. 1.600



Pack-2 urinals

Code 65220
Package weight: Kg. 1.450

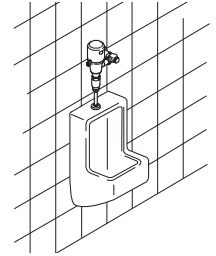

Kit AUT-1

Code 65215
Package weight: Kg. 2.200



Kit AUT-2

Code 65218
Package weight: Kg. 2.200

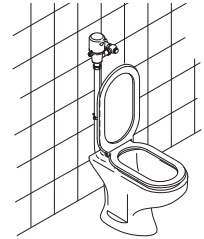

Kit FRT

Code 61527
Package weight: Kg. 3.100

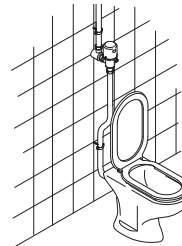

Kit LT

Code 61528
Package weight: Kg. 2.600



Plumbing kits are not included in prices but purchasable separately.

Certifications: **CE EMC HACCP D.M.174 PG**

Overview:

The electronic RIOMATIC system activates when the user enters the sensors' field of action for at least 6/8 seconds. When the user moves away, water is fully flushed from the cistern on the WC.

Power:

- Safety Transformer: 230Vac - 24Vdc, manufactured in compliance with CEI EN 61558-1/-2-6 requirements

Features:

- DMP photocell sensors, made of scratchproof and calcium resistant material
- Fully waterproof resined electronic circuit
- Stainless steel external plate with vandal-proof screws
- DMP software programmed microchip for perfect function control
- Water flush about 2 seconds after the user leaves the sensors' field of action (after remaining in the field of action for more than 6/8 seconds). To let water fill the cistern and, therefore, guarantee the next full flush, the detector remains active for 60 seconds after flushing

- 70 mm deep recessed cistern
- Optional: Sensor with hand approach activation
- Siphon flush system to be installed inside the high cistern (not included)
- Vandal-proof plate fastening screws

Technical Specifications:

- Electronic circuit: 24 V, manufactured in compliance with CEI EN 55014-1/-2 requirements
- Drain with 24V coil and 300 cm long cable
- Sensors' range of action: 20 - 80 cm
- Water pressure: 0.4 - 5 bar

Package Contents:

- Electronic control for WC with top cistern RIOMATIC with drain (not included)
- Vandal-proof key for plate fastening
- Accessories for fixing the siphon to the cistern
- Instruction manual
- DMP safety transformer

Recommended for:



Public



Industry

Riomatic 100



08416 Chrome
08413 White

Power: 24 V transformer
Package weight: Kg. 3.500
Availability: 10 business days
Electronic flushing for WCs with cistern
High cistern and plumbing not included

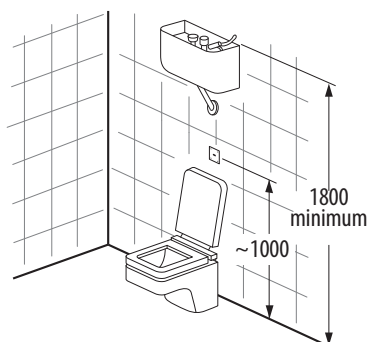





Furniture and Washbasins

Aesthetics and durability are perfectly combined in Corian®, a material that adapts to any type of processing: cutting, drilling, engraving and lapping. It can be shaped, heat-formed and invisibly glued. For this reason, even the most complex design can be created. Furthermore, the perfect continuity between the surface and washbasin, without offsets or joints, guarantees absolute hygiene. In all situations, Corian® is always at its best. Since it is a homogeneous material, it can be repaired without any problem, ensuring long-lasting and high stability in its value. Additionally, it is fully bio-compatible and does not harm the environment.



Panels and Dividing Walls

Made of HPL, a high pressure laminate, our walls are available in a vast range of formats, thicknesses and shapes. They do not absorb humidity, have full resistance against vandalism, are easy to process and clean, aesthetically pleasant with advanced technical features, they are ideal for the construction sector. Eco-friendly, HPL panels and dividing walls adapt to every design and furnishing need. Even dividers for urinals are made up of an HPL laminate panel, supported by a polished stainless steel bracket. Our panels are practically indestructible and grant any restroom order and cleanliness.



Colours Available



411 White



414 Sand



475 Pearl grey



464 Light yellow



861 Pop yellow

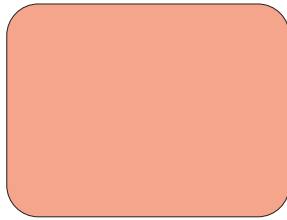

866 Champagne yellow

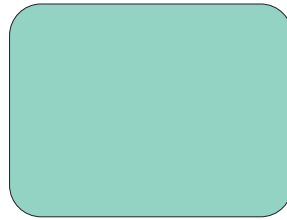

846 Turquoise



441 Citron green

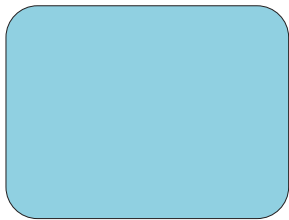

857 Mysotis blue

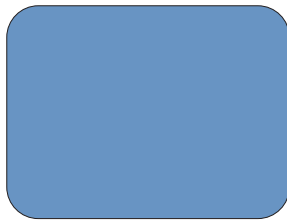

484 Sapphire blue

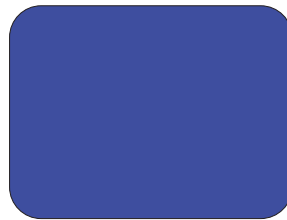

428 Electric blue



856 Steel blue

Installation examples

This is only one of the numerous installation possibilities for our accessorised wall systems.

We are able to fulfill custom orders for any type of room.

Delivery time: 40 business days.

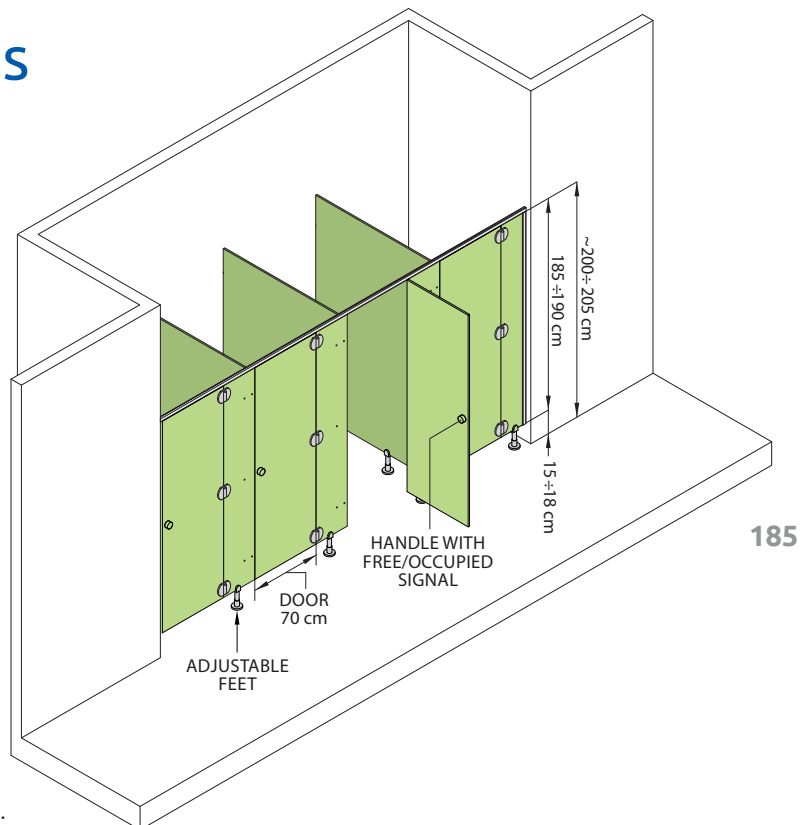
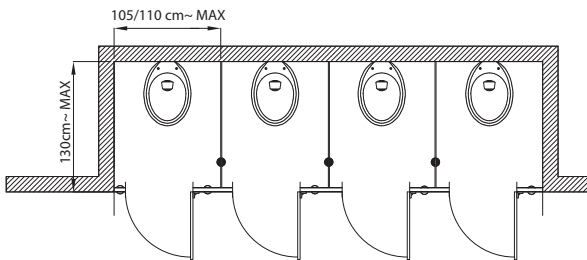

The colours on this page are for illustrative purposes.

Techno-Structures for Drywall

DMP Electronics, always attentive to changes in customer demands, offers new, simple, safe and flexible solutions for DMP product installation on drywalls. These special brackets, to be installed on new or existent structural uprights, are adjustable from 57 to 66 cm, thus adaptable to sector standards. Other applications can be assessed with the DMP engineering support department upon request.

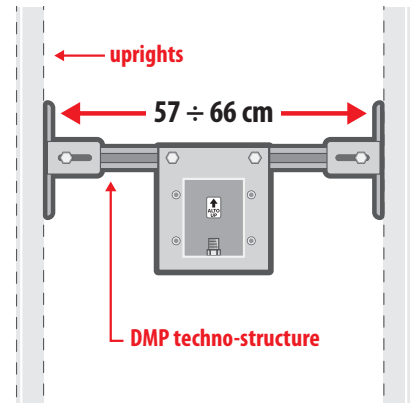

Code 55503

For **Ovalis** (page 20) electronic tap



Code 55506

For **Quadro Q** (page 24) and **Quadro T** (page 28) electronic taps



Code 55509

For **MiniUno 40** (page 32) electronic tap



Code 55512

For **MiniUnoMix 40** (page 32) electronic tap



Code 55515

For **Speedy** (page 96) electronic tap



Code 55518

For **Speedymix Comp** (page 100) electronic tap



Code 55521

For **Uno** (page 104) electronic tap



Code 55524

For **Speedy Comp** (see DMP Price List) electronic tap



Code 55527

For **SplashMix** (page 142) electronic shower



Code 55530

For **Spin** (page 142) electronic shower



Code 55533

For **Fin** (page 154) electronic urinal



Code 55536

For **Flush Comp** (page 158) electronic urinal



Code 55539

For **Saniflush** (page 162) electronic urinal



Codici a page 171

For **Dikaflush Tecno** (page 171) electronic WC



Code 55545

For **M-Lux** and **M-Fix** (page 172) electronic WC

Integrated Solutions for Bathroom Furnishings



Chrome Kit
page 12



White Kit
page 14



Public Kit
page 16



Home Kit
page 18

Electronic Tapware | Top Collection



Ovalis
page 20



Quadro Q
page 24



Quadro T
page 28



MiniUno 40
page 32

Electronic Tapware | All-in-One



Class Metal
page 36



Class Abs
page 40



Cento Tap
page 44



Quary Tap
page 48

Electronic Tapware | Compact



Comfort
page 52



Compacto
page 56



Dia
page 60



Eco Plus
page 64



Sette
page 68



Tube Plus
page 72

Electronic Tapware | Long Spout



Arco Plus
page 76



Billo
page 80



Billo Plus
page 84

Electronic Tapware | with Extension



Arco Plus RZ
page 88



Tube Plus RZ
page 90

Electronic Tapware | Wall Mounted



MiniUno 32
page 92



Speedy
page 96



Speedymix Comp
page 100



Uno
page 104

Electronic Tapware | Kitchen



Joy
page 108



Oceanus
page 112

Washbasins for Public Washrooms



Sanikit
page 116



Sanitech
page 118

Electronic Soap Dispensers



Sanisoap Inox
page 120



Sanisoap Abs
page 124



Quary Soap
page 128

Electronic Hand Dryers



Turbo
page 130



Aria
page 134

Automatic Hair Dryers



PickUp
page 138



Jolly
page 138

Electronic Showers



Splash
page 142



Spin
page 142



Nilo
page 146



Sc 345
page 146



Dce 28
page 150



Dce 28 Tag
page 150

Electronic Urinals



Fin
page 154



Flush Comp
page 158



Saniflush
page 162



River Extra
page 166

Electronic WCs



Dikaflush
page 168



M-Lux / M-Fix
page 172



Fm 14300
page 176



Riomatic
page 180

DMP Furnishings



Furniture and Washbasins
page 182



Panels and Dividing Walls
page 184

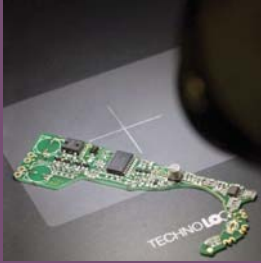

DMP Electronics Srl | Via Maestri del Lavoro, 1 | 64020 Canzano (TE) - Italy
T +39 0861 2046 | F +39 0861 232000 | www.dmpelectronics.com | info@dmpelectronics.it

43

12

EN



www.dmpelectronics.com

www.parsital.com